



CORE LINEPIPE



**PROJECT
EXECUTION
GUIDE**

VERSION 10 | MAY, 8 2023

TABLE OF CONTENTS

1. Introduction	5
1.1 Project Execution Program	5
1.2 CORE Linepipe®	5
1.3 CORE Safety	5
1.4 CORE Quality	6
1.5 CORE Engineering	6
1.6 CORE Manufacturing	6
1.7 CORE Construction	6
2. CORE Liner®	7
2.1 General	7
2.2 ClickWeld®	7
2.3 Electrofusion	8
2.4 Bends	9
2.5 Risers	10
2.6 Flanges	10
2.7 Flow Joints	11
3. Bidding a CORE Liner® Project	12
3.1 Introduction	12
3.2 Explanation of a CORE Offer	12
3.3 CORE Required Support from Contractor	14
3.4 Contractor Responsibilities	14
3.5 Scope of CORE Service®	15
3.6 Purchased from CORE Linepipe® by Client	15
3.7 CORE Liner® vs. Coiled	16
3.8 CORE Liner® vs. Pulled	17
3.9 CORE Liner® vs. Spooled	18
3.10 CORE Liner® vs. Fiberglass	19
3.11 CORE Liner® vs. HDPE	21
4. Manpower & Equipment Loading	22
4.1 Productivity	22
4.2 CORE Productivity Metrics	22
4.3 Weather Considerations	22
4.4 CORE Service® KPI's	23
4.5 CORE Efficiency & Intraday Utilization	23
4.6 How to Efficiently Use CORE	23
4.7 Examples of Highly Utilized & Poorly Utilized	24
5. Setting-up for Success	26
5.1 Pre-Job Kickoff	26
5.2 Rise Modules for Onsite Staff	26
5.3 Rise Modules for Estimating/Project Management	28
5.4 External Coating Training	28
5.5 CORE Documentation	28
5.6 Senior Staff Support	28
5.7 Project Update & Performance Meetings	28
5.8 Daily On-Site Planning & Communication	28
5.9 Daily Efficiency Reports	29
6. Installation Planning	30

6.1	<u>ROW Setup</u>	30
6.2	<u>Directional Assembly</u>	30
6.3	<u>Pipe Position</u>	31
7.	<u>Pipe on Site</u>	32
7.1	<u>Pipe Delivery</u>	32
7.2	<u>Pipe Storage</u>	33
7.3	<u>Pipe Stringing</u>	34
7.4	<u>Pipe End Protection</u>	35
8.	<u>Pipeline Construction</u>	36
8.1	<u>General Mainline Construction & Personnel Allocation</u>	36
8.2	<u>Mainline Crew Configuration</u>	37
8.3	<u>ClickWeld®</u>	39
8.4	<u>Electrofusion</u>	39
8.5	<u>Night Capping</u>	40
8.6	<u>ROW Bends</u>	40
8.7	<u>Ditch Profile</u>	42
8.8	<u>Bell Hole</u>	42
8.9	<u>Tie-Ins</u>	43
8.10	<u>Custom Length</u>	44
8.11	<u>Joint & Repair Coating</u>	45
8.12	<u>Holiday Detection</u>	45
8.13	<u>Lowering In</u>	46
8.14	<u>Line Crossings</u>	46
8.15	<u>HDD and Boring</u>	47
8.16	<u>Risers</u>	48
8.17	<u>Flanged Connections</u>	49
8.18	<u>Annular Vents</u>	49
8.19	<u>Buoyancy Control</u>	49
8.20	<u>Electrical Isolation</u>	49
8.21	<u>Cathodic Protection</u>	49
9.	<u>Quality Control</u>	50
9.1	<u>Quality Management System</u>	50
9.2	<u>ClickWeld®</u>	51
9.3	<u>Hydrotest Procedure</u>	51
9.4	<u>Bore Section Hydrotest Procedure</u>	51
9.5	<u>Pipeline Quality Control</u>	51
10.	<u>Returning Material</u>	52
10.1	<u>Return Policy</u>	52
10.2	<u>Return Procedure</u>	52
1.	<u>APPENDIX</u>	53
1.1	<u>Appendix A: Data Sheet</u>	54
1.2	<u>Appendix B: Flanged Ends Bulletin</u>	59
1.3	<u>Appendix C: Pre-Job Kickoff</u>	64
1.4	<u>Appendix D: External Coating Bulletin</u>	73
1.5	<u>Appendix E: Flange Bolt Up Specification</u>	94
1.6	<u>Appendix F: Exothermic Welding Bulletin</u>	84
1.7	<u>Appendix G: Hydrotest Procedure</u>	86
1.8	<u>Appendix H: Returning Material</u>	92
1.9	<u>Appendix I: Start Up, Operation & Shut Down Bulletin</u>	93



1. INTRODUCTION

1.1 PROJECT EXECUTION PROGRAM

The Project Execution Program is designed to provide the information needed by personnel bidding, planning, or executing CORE Liner® pipeline projects.

This program consists of two components:

- Rise Project Execution Modules – A high-level summary of the essential points in combination with some task-based information modules.
- Project Execution Guide – Presents the information required while working with CORE Linepipe® products.

1.2 CORE LINEPIPE®

Who We Are

CORE Linepipe® prides itself on providing a cost-effective pipeline system that offers superior corrosion resistance and dual containment, backed by zero environmental releases since beginning operations in 2014.

CORE Linepipe® is a pipeline technology company focused on innovative solutions that rethink traditional pipeline systems. CORE's goal is to change how pipelines are constructed by shifting the focus to factory installation over fieldwork.

CORE Linepipe® has a world class team consisting of energy pipeline veterans who have a proven track record building relationships with clients and delivering positive results, thriving where others cannot.

Zero Environmental Releases

With over 50 clients across North America, CORE Linepipe® has successfully developed a reliable pipeline system with over 800 km (500 mi) installed to date (2014 to year-end 2022).

Since its incorporation in 2012, CORE has maintained ZERO environmental releases or in-service failures. Providing a dual containment, corrosion-resistant system, CORE exceeds industry ESG (Environmental, Social and Governance) standards.

In addition to supplying a high-quality product, CORE also takes pride in providing high-quality, cost-saving pipe joining services.

1.3 CORE SAFETY

The safety of all stakeholders is paramount to CORE Linepipe® Leadership. Safety is embedded throughout the development of every strategy, system, process, product, and service offering. The CORE Linepipe® team takes pride in our safety culture that is built on:

- The engineering of safety into systems, processes, products, and equipment designs.
- Critical assessment of hazards and work procedures to ensure the safe and efficient operation by production and field personnel.
- Documentation of processes, inspections, near misses, incidents, and daily toolbox talks for training, monitoring, and compliance.



1.4 CORE QUALITY

CORE Linepipe® utilizes an extensive quality assurance and quality control program that adheres to international standards and utilizes Lean and Six Sigma methodologies to ensure we are industry leaders.

CORE Linepipe® policies and procedures provide complete traceability from production to installation, delivering a complete documentation package to every client upon project completion. CORE Linepipe® has a quality commitment that allows our client to focus on everything else.

CORE's QMS is ISO 9001 certified as of November 2022.



1.5 CORE ENGINEERING

CORE's engineering and product development team brings world-class expertise in product development, machine design, qualification testing and oil and gas applications. All design work for products, manufacturing equipment, and field equipment has been completed in-house.

[\(Video\) FEA Factory Bell & Ring Engagement](#)

1.6 CORE MANUFACTURING

CORE Linepipe® has a state-of-the-art manufacturing facility located about 30 minutes North of Calgary in Crossfield, Alberta, Canada. Sitting on 9 acres, the 60,000 square foot manufacturing centre can produce up to 1200 km/800 miles of pipe per year in sizes from 4" to 8". Product sizes 10" and 12" are under development for 2023.

1.7 CORE CONSTRUCTION

CORE Linepipe® has a primary field services center located in Crossfield, Alberta, and satellite service depots in Texas and Colorado. CORE Service® crews are self-sufficient in the field, operating out of a mobile workshop and storage trailer that is fully equipped with all required tooling, components, and consumables to complete a job.

2. CORE LINER®

2.1 GENERAL

CORE Liner® is a corrosion resistant, dual containment pipe-in-pipe system that combines the high-pressure capacity of steel with the corrosion resistance of plastics, utilizing an outer steel pipe with a pre-installed inner HDPE liner. This pipe-in-pipe system provides true dual containment as well as internal and external corrosion resistance from flange to flange.

To complete the ClickWeld® joining system, two pipe ends are joined together (factory-end and field-end). The internal HDPE liner is joined using an electrofusion process. The result is less field work, lower total cost of ownership, and increased reliability for the pipeline system. The structural steel pipes provide the pressure capacity, secondary containment and are joined together using the CORE Linepipe® proprietary ClickWeld® system.

The internal plastic liner provides corrosion resistance, primary containment and is joined using an integral electrofusion process.

[\(Video\) ClickWeld® Animation](#)

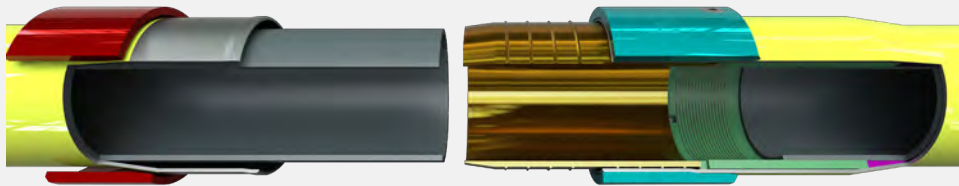

2.2 CLICKWELD®

ClickWeld® is the innovative proprietary mechanical joining system of CORE Linepipe®. The ClickWeld® system uses high grade carbon steel components to form a connection that is gas and liquid tight, eliminating the need for field welding.

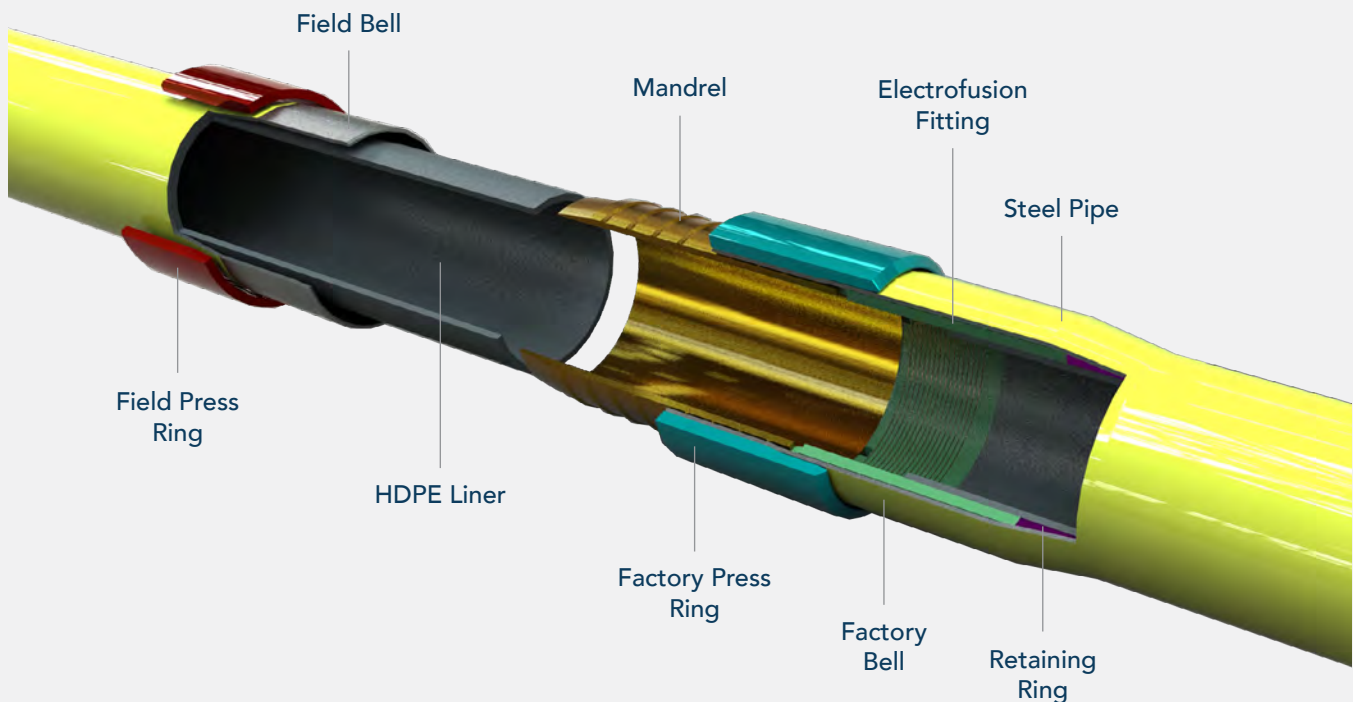

Assembly Is An 7-Step Process:

At the Production Plant:

1. Belled steel factory end is created
2. Liner, electrofusion (EF) coupling, and retaining ring is inserted into the steel pipe
3. A mandrel is inserted inside the bell, butted up to EF coupling
4. A factory ring is pressed over the bell completing the factory connection

In the Field:

5. Field and factory ends are stabbed together
6. The field bell is pulled over the mandrel
7. The field ring is finally pressed, deforming the pipe onto the mandrel's profile, completing the ClickWeld® joint.

2.3 ELECTROFUSION

Premium Electrofusion fittings (EF) serve as an alternative to butt fusion for HDPE joining.

CORE Liner® Dual Zone EF consists of an HDPE coupling with copper wiring embedded inside. That wiring is connected to an electrofusion control unit (ECU) that fuses the coupling and HDPE pipe, creating a homogeneous joint stronger than the parent pipe.

The ECU measures and records a variety of data, adjusts fusion/soak time to account for ambient temperature and ensures continuity of the wiring. This data is included in CORE Liner® quality and traceability documentation.

EF's have more than 70 years of usage and are commonplace in gas distribution and offer significant advantages over butt fusion.

Advantages:

- 7 times the strength and surface area of a perfect butt fusion
- Reinforces the liner against radial collapse
- Anchors the liner against axial collapse
- Increased quality control on all joints due to the Electrofusion Control Unit
- Easier pigging through the full-bore profile at the joint

[\(Video\) Introduction to Electrofusion](#)

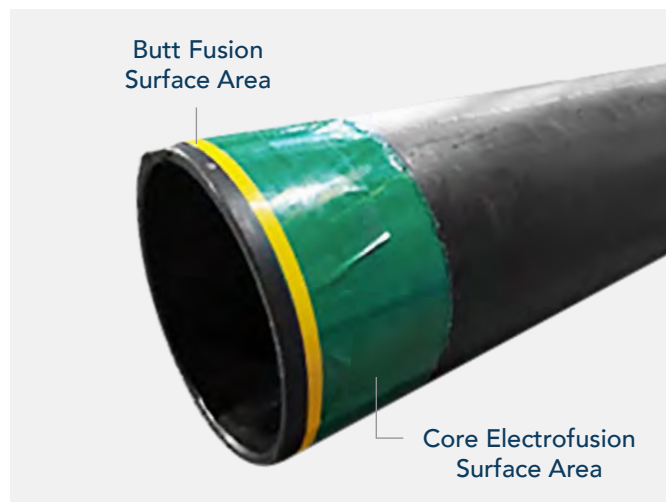

CORE LINER® PRODUCT	LINER OD (in)	LINER THICKNESS (in)	ELECTROFUSION AREA (in ²)	TRADITIONAL BUTT FUSION AREA (in ²)	EF IMPROVEMENT VS BUTT FUSION
CL440	4.18	0.23	38.00	2.85	13x
CL640	6.30	0.25	53.38	4.79	11x
CL648	6.24	0.25	52.87	4.71	11x
CL671	6.06	0.24	49.84	4.39	11x
CL856	8.18	0.32	74.32	8.06	9x
CL1071	10.10	0.41	93.69	12.35	7.5x
CL1279	12.05	0.48	112.57	17.59	6.5x

2.4 BENDS

The standard (and minimum) bend radius of CORE Liner® is 20D and must be cold bent to ensure the internal liner and steel are not compromised. CORE Liner® products can easily be field bent using standard field bending equipment. Bends greater than 30° can be factory bent, improving QA/QC, and saving time in the field, and must be pre-ordered and approved by the client.



2.5 RISERS

CORE Liner® risers are factory bent and are available in 45° or 90°. CORE Liner® risers allow clients to have a corrosion resistant pipeline from flange to flange, without having to resort to expensive internal coatings. CORE Liner® risers must be pre-ordered and client sign-off on the CORE Liner® riser drawings is required prior to bending to assure delivered dimensional quality.

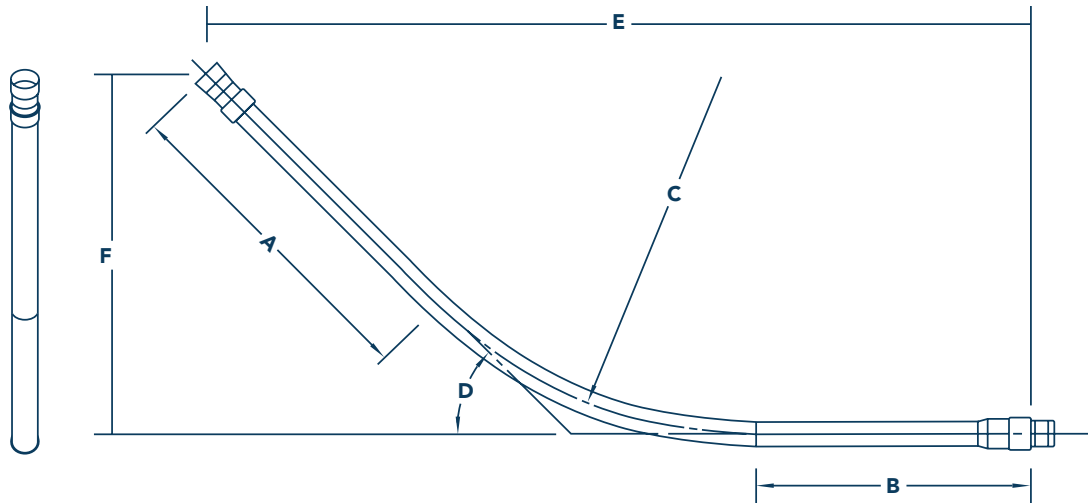

Note: D is the angle in degrees and C is the turning radius in mm or inch.

2.6 FLANGES

Flanges are to ASME B16.5 and are joined to the CORE Liner® pipeline using the patented ClickWeld® joining system. Each flange connection comes with an HDPE stub end, ClickWeld® components, and an electrofusion fitting to easily connect to an existing CORE Liner® pipeline. The design of the flange assembly has safeguards against excessive strain on the HDPE stub end, thereby eliminating a failure mode common to other liner systems.

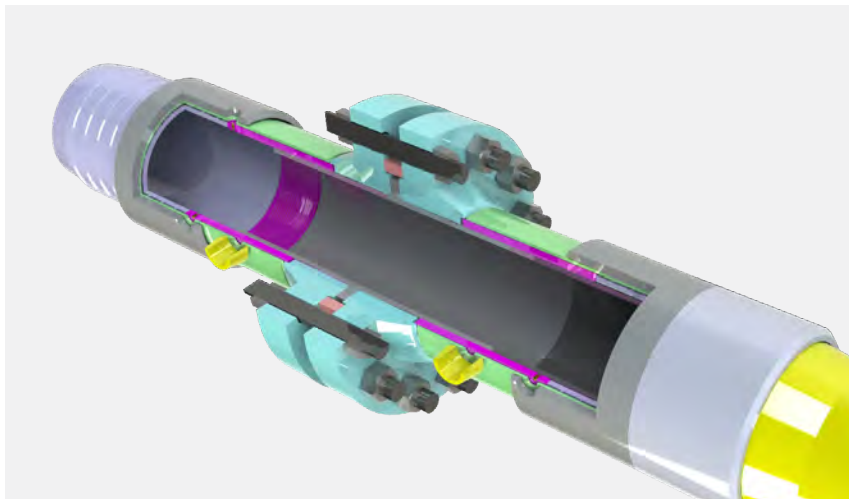

2.7 FLOW JOINTS

CORE Linepipe® can supply custom stainless steel, flanged, Flow T's and Y laterals upon request. Flanged flow joints are easily integrated into the CORE Liner® system. Alternatively, lap joint, raised faced flanged carbon steel flow joints can be fabricated and internally coated by a third party. Please contact a CORE Linepipe® representative for guidance.

PRODUCT DESCRIPTION	ID (in)	ID (mm)
CL440	3.72	94
CL640	5.81	148
CL648	5.74	146
CL671	5.59	142
CL856	7.52	191
CL1071	9.37	238
CL1279	11.14	283

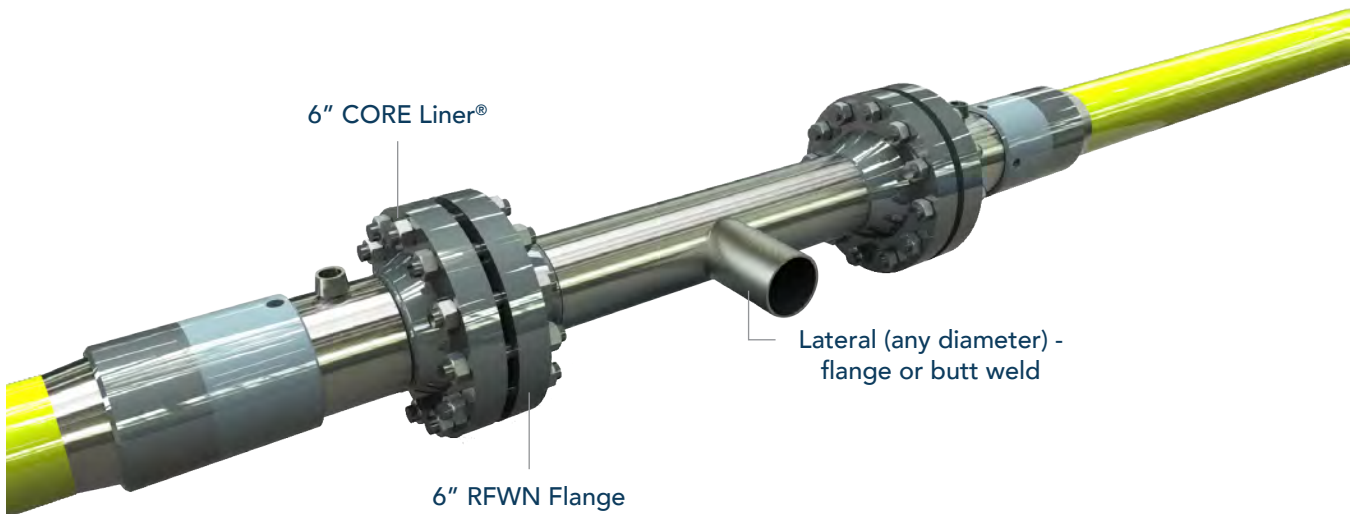

3. BIDDING A CORE LINER® PROJECT

3.1 INTRODUCTION

The CORE Service® team integrates into any conventional pipeline spread. The CORE Liner® system and CORE Service® team eliminate the need for pipeline welding (except for flow joint fabrication and pile supports). At a high level, the CORE Service® team replaces conventional welding and liner crews. All other activities on the project will operate as they normally would for a steel pipeline project.

Benefits of a CORE Liner® project:

- No welding
- No x-ray
- No additional rentals
- No reel returns
- No deployment equipment rentals
- No charges for joining system materials
- No pipe heating
- No partial pipe lengths and minimal waste
- No casings required on bores
- No cranes required for off-loading

3.2 EXPLANATION OF A CORE OFFER

CORE Linepipe® proposals include all materials required to complete a CORE Linepipe® pipeline (pipe, external coating, internal liner, internal electrofusion, ClickWeld® joint, flanges, bends, risers, vents, external joint protection, and all consumables.) In addition to the material estimate, CORE Linepipe® provides a construction estimate that covers all CORE Service® field activities.

CORE Linepipe® estimates are based on historical installations in the project area, a thorough review of the survey that includes crossings, bore sections and riser sites, and also accounts for seasonal construction considerations.

CORE Linepipe® uses data collected since the first CORE Liner® installation in 2014, to estimate project duration, productivity, etc. The intention is to set realistic expectations for the project duration to allow clients to issue AFE's with cost certainty.



CORE Linepipe
910, 736 – 8th Avenue S.W.
Calgary, AB
www.CORELinepipe.com

CORE Liner Quotation

Date: 11/22/22
Quote #: SQ00000300
Job #: J00004710
Shipping: Ex Works, Crossfield, AB

CUSTOMER:
 Canada Goose Energy Partners
 Martin Nelson
 403-827-6090
 mnelson@cge.ca

LOCATION:
 NW
 NE
 Drayton Valley

CORE Contact:
 Aethan Sakell
 (403) 589-3012
 asakell@corelinepipe.com

Item #	Qty	CORE Liner Material	Description	Unit Price		Amount (CAD)
1059	2,834	CL856, CSA Z245.1, Grade 359 Category II M45C SS ERW Pipe, YJ2K External Coating		\$50.00	m	\$141,700.00
1090	2	CL856 Flange CSA Z245.12 PN 100 (ANSI 600) Grade 359 Category II M45C SS		\$1,500.00	ea	\$3,000.00
SI001	2	Riser Vents		\$150.00	ea	\$300.00
1182	2	CL856 Riser Bend (CSA Z245.11 GR359 Category II M45C SS)	2 x 45	\$4,000.00	ea	\$8,000.00
1182	2	CL856 ROW Bend (CSA Z245.11 GR359 Category II M45C SS)	3 x 90	\$4,000.00	ea	\$8,000.00
1406	120	STOPAQ Wrappingband CZH / HT 100mm x 10m		\$50.00	ea	\$6,000.00
1407	69	STOPAQ Wrappingband CZH / HT 50mm x 10m		\$40.00	ea	\$2,760.00
1409	69	STOPAQ Outerwrap HTPP 100mm x 30m		\$90.00	roll	\$8,694.00
Material Subtotal						\$178,454.00
Item #	Qty	CORE Service	Description	Unit Price		Amount (CAD)
0011	11	Day Rate Main-line		\$1,800.00	day	\$19,800.00
0030	2	Mob-DeMob	(*All Men + Trucks)	\$5,000.00	day	\$10,000.00
0070		Third Party Hauling		Cost + 15%		
	7	Pipe Freight		Cost + 15%		\$35,000.00
0020		Standby	(*Subsistence not incl.)	\$1,300.00	day	
0040		Subsistence		\$185.00	md	
Service Subtotal						\$64,800.00
Sub-Total						\$243,254.00
GST						\$12,162.70
Total						\$255,416.70
Effective \$ per meter						\$85.83

Note: Quote does not display actual prices.

3.3 CORE REQUIRED SUPPORT FROM CONTRACTOR

CORE Linepipe® requires the following support from the contractor:

- In-field CORE Linepipe® equipment mobilization
- Mainline - dedicated side boom with operator and personnel (100% of joining duration) to support the CORE Service® team. Additional equipment is required in scenarios where CORE is providing a 2-person crew.
 - In the absence of dedicated support equipment, the ClickWeld® process cannot be completed.
- Tie-ins - Two lifting implements are required to support the CORE Service® team for in the ditch tie-ins and risers (additional equipment may be needed depending on project conditions)
- Excavation of bell holes to CORE specifications (tie-in access)

**Without dedicated support, CORE Linepipe® is unable to work*

3.4 CONTRACTOR RESPONSIBILITIES

- Licenses and permits
- Site preparation and access
- Pipeline right-of-way preparation (min 15m / 50ft)
- Strip, ditch, lower, and backfill
- Pipe stringing including all equipment and personnel
- Minimum 1m / 3.3ft required between multiple lines in ditch to complete in ditch tie-in
 - Standard steel pipe spacing is acceptable for final ditch position
- Pipe handling, positioning, rotating, aligning, and stabbing
- Field bending
- Equipment, material, and personnel for crossings/bores/HDD
- Installation of external corrosion protection on ClickWeld® joint
- Pipe jeepling
- Supply and installation of coating repair materials and personnel
- Support pile and hardware for risers
- Bolt up of all flanges, including supply of studs, washers, and nuts
 - Stud Length Chart (See [Appendix E: Flange Bolt Up Specification](#))
- Flange electrical isolation material
- Hydrotest including fluids and disposal
- Supply and install consumables as needed
- Pipeline quality control
- Reclamation of ROW including back fill
- *All other typical activities not specified under CORE's scope of work*

3.5 SCOPE OF CORE SERVICE®

The following items are included in the scope of CORE Service® and included in the day rate:

- Review of drawings
- Collaborate on the development of detailed proposals and schedule
- Site visit – suggested for projects over 5km / 3miles
- Coordinate delivery of pipe, bends, and ancillary materials to site
- Supply of self-contained joining equipment and crew
- Completion of all ClickWeld® joints
- Completion of all cuts and tie-ins
- Supply ClickWeld® pull head
- Supply CORE Liner® QC package
- Supply material MTRs

3.6 PURCHASED FROM CORE LINEPIPE® BY CLIENT

The following items are purchased from CORE Linerpipe® by the client:

- CORE Liner® pipes
- CORE Liner® risers/bends (bends >30° are recommended to be factory bent)
- ClickWeld® flanges and transition pups
- Supply of external coatings material for ClickWeld® joints
- Supply and installation of riser vents
- Pipe and material freight
- CORE Service® joining activities
- Mob/demob of CORE Service® team and equipment

3.7 CORE LINER® VS. COILED RTP'S

Clients have an expectation that the per foot/meter unit lay rate for CORE will be roughly the same as coiled pipe (project scope and conditions dependent). The table below outlines the contractor scope of work for construction of a pipeline with CORE compared to coiled pipe.

JOB ACTIVITY	CORE LINER®	COILED RTP'S
ROW Prep	Neutral	Neutral
Deployment trailer rentals	Not required	Required
Off-loading prior to stringing	Not required	Required
Stringing	Neutral	Neutral (Increased in cold temperatures)
Pipe heating	Not required	Required
Rentals / Fitting tech	Not required	Required
Pipe joining crew / Equipment	Supplied by CORE	Required
Joining crew logistics	Dedicated through project	Variable
Pipe bending	Required	Not required
Ditching	Neutral	Neutral
Lowering in	Neutral	Neutral
Tie-ins	Neutral	Neutral
Joint coating	Increased	Neutral
Jeeping	Required	Not Required
Sacrificial anode	Not required	Required
Tracer wire	Not required	Required
Backfill	Neutral	Neutral
Hydrotest	Neutral	Neutral
HDD	Neutral	Neutral
Crossings	Neutral	Neutral
Mechanical support for joining	Required	Required
Welds NDE	Not required	Not required
Tie-in bell holes	Minimal	Minimal
Project duration	Neutral	Neutral
Rental returns	Not Required	Required
Material waste	Reduced	Increased

3.8 CORE LINER® VS. PULLED LINER

Clients have an expectation that the per foot / meter unit lay rate for CORE will be significantly lower than a traditionally pulled liner system. The table below outlines the contractor scope of work for construction of a pipeline with CORE compared to pulled liner.

JOB ACTIVITY	CORE LINER®	PULLED LINER
ROW Prep	Neutral	Neutral
Stringing	Neutral	Neutral
Rentals / Fitting tech	N/A	N/A
Ditching	Neutral	Neutral
Lowering in	Neutral	Neutral
Tie-ins	Neutral	Neutral
Joint coating	Neutral	Neutral
Jeeping	Neutral	Neutral
Backfill	Neutral	Neutral
1st Hydrotest	Neutral	Neutral
HDD	Neutral	Neutral
Crossings	Neutral	Neutral
Mechanical support for joining	Neutral	Neutral
Welds NDE	Not Required	Required
2nd Hydrotest	Not Required	Required
Pull-point bell holes	Not Required	Required
Tie-in bell holes	Neutral	Neutral
Project duration	Reduced	Increased

3.9 CORE LINER® VS. SPOOLED RTP'S

Clients have an expectation that the per foot/meter unit lay rate for CORE will be roughly the same as spooled linepipe (project scope and conditions dependent). The table below outlines the contractor scope of work for construction of a pipeline with CORE compared to spooled pipe.

JOB ACTIVITY	CORE LINER®	SPOOLED PIPE
ROW Prep	Neutral	Neutral
Deployment trailer rentals	Not required	Required
Off-loading prior to stringing	Not required	Required
Stringing	Neutral	Neutral (Increased in cold temperatures)
Pipe heating	Not required	Required
Rentals / Fitting tech	Not required	Required
Pipe joining crew / Equipment	Supplied by CORE	Required
Joining crew logistics	Dedicated through project	Variable
Pipe bending	Required	Not required
Ditching	Neutral	Neutral
Lowering in	Neutral	Neutral
Tie-ins	Neutral	Neutral
Joint coating	Increased	Neutral
Jeeping	Required	Not Required
Sacrificial anode	Not required	Required
Tracer wire	Not required	Required
Backfill	Neutral	Neutral
Hydrotest	Neutral	Neutral
HDD	Neutral	Neutral
Crossings	Neutral	Neutral
Mechanical support for joining	Required	Required
Welds NDE	Not required	Not required
Tie-in bell holes	Minimal	Minimal
Project duration	Neutral	Neutral
Rental returns	Not Required	Required
Material waste	Reduced	Increased

3.10 CORE LINER® VS. FIBERGLASS

The table below outlines the contractor scope of work for construction of a pipeline with CORE compared to fiberglass pipe.

JOB ACTIVITY	CORE LINER®	FIBERGLASS PIPE	FIBERGLASS DETAILED REQUIREMENTS
ROW Prep	Neutral	Neutral	
Stringing	Neutral	Neutral	
Rentals / Fitting tech	N/A	N/A	
Pipe joining crew / Equipment	Supplied by CORE	Required	
Pipe bending	Capable	Not capable	<ul style="list-style-type: none"> • Elbows must be used • Pipe can't be bent in field
Ditching	Neutral	Increased	<ul style="list-style-type: none"> • Sloped ditch wall, flat stable ditch bottom to avoid joint deflection • Avoid over excavation (cellars)
Lowering in	Neutral	Neutral	
Tie-ins	Neutral	Neutral	
Joint coating	Required	Not required	
Tie-in bell holes	Minimal	Minimal	
Fitting / PUP / Elbow install	Not required	Required	<ul style="list-style-type: none"> • 12m / 40ft of straight pipe required leading into a riser • 3 joint minimum when connecting to a steel riser
Jeeping	Required	Not required	<ul style="list-style-type: none"> • Stick fiberglass is a full-bonded material, the fibers encased in the epoxy matrix are responsible for the pressure-containing capabilities of the product • As there is no protective layer on fiberglass, impacts or rough handling of the product can result in 'bruising' of the pipe
Backfill	Neutral	Increased	<ul style="list-style-type: none"> • Selective backfill required • Loose, unfrozen soil with no rocks permitted
Sand Bedding, Raking, Cover	Not required	Required	<ul style="list-style-type: none"> • Selective backfill required • Loose, unfrozen soil with no rocks permitted
1st Hydrotest	Neutral	Neutral	<ul style="list-style-type: none"> • Joints need to be visible for inspection during hydrotest • High pressure 1524m / 5000ftmax, low pressure 762m / 2500ft

HDD	Neutral	Increased	<ul style="list-style-type: none"> • Cased centralizers, sand bags, and end seals required for road crossings • Tensile rating limitations - 1/3 of CORE
Crossings	Neutral	Increased	<ul style="list-style-type: none"> • Mechanical protection for abrasion required at crossings
Tracer wire	Not required	Required	
Pipe joining	CORE supplied	Required	<ul style="list-style-type: none"> • Debris will inhibit connections • O-rings, pipe dope, and Teflon tape must be warmed • At least 150% of the number of connections (based on 12m / 40ft joints) • Additional cure time of epoxy or • Lubricants or heating required at joints • Only one attempt permitted to rework failed joints
Mechanical support for joining	Required	Required	
Welds NDE	Not required	Not required	
2nd Hydrotest	Not required	Not required	
Project Duration	Reduced	Increased	

3.11 CORE LINER® VS. LARGE DIAMETER HDPE

The table below outlines the contractor scope of work for construction of a pipeline with CORE compared to large diameter HDPE.

JOB ACTIVITY	CORE LINER®	LARGE DIAMETER HDPE
ROW Prep	Neutral	Neutral
Deployment trailer rentals	Not required	Not required
Off-loading prior to stringing	Not required	Not required
Stringing	Neutral	Neutral
Pipe heating	Not required	Required
Rentals / Fitting tech	Not required	Not required
Pipe joining crew / Equipment	Required	Required
Joining crew logistics	Neutral	Neutral
Pups & elbows	Not required	Required
Ditching	Neutral	Neutral
Lowering in	Neutral	Neutral
Tie-ins	Neutral	Neutral
Joint coating	Required	Not Required
Jeeping	Required	Not Required
Sacrificial anode	Not required	Not Required
Tracer wire	Not required	Required
Backfill / Ditching padding	Not required	Required
Hydrotest	Neutral	Neutral
HDD	Casing not required	Casing required
Crossings	Neutral	Neutral
Welding	Not required	Not required
Mechanical support for joining	Neutral	Neutral
Welds NDE	Not required	Not required
Tie-in bell holes	Minimal	Minimal
Project duration	Decreased	Increased
Rental returns	Not Required	Not required
Material waste	Neutral	Neutral
Weather limitations	Decreased	Increased

4. MANPOWER & EQUIPMENT LOADING

4.1 PRODUCTIVITY

The productivity rate of the CORE Service® team is a function of the time of year, scope of project, manpower and equipment loading schedule, and overall project execution methodology.

The CORE Service® team works diligently to ensure timely project execution. Please refer to the sales order for expected CORE Service® on-site crew days which is based on historical production rates in the project area, season, complexity of tie-ins, bore sections, and crossings.

To ensure the most efficient and cost-effective installation, planning, and collaboration between the CORE Service® team and contractor team is critical. Plans should be in place to eliminate non-productive time (defining required support, sequence, and access to tie-ins, planning bends etc.)

The expected CORE Service® crew rotation is 24 days on and 5 days off (excluding travel time). This is based off the current OH&S guidelines in Canada.

For projects in the US or in other jurisdictions CORE Linepipe® can accommodate a custom crew rotation as needed.

4.2 CORE PRODUCTIVITY METRICS

CORE PRODUCTIVITY METRICS		
Activity	Required Time	Unit of Measure
ClickWeld®	7-15	Minutes
Stab On Tie-in	0.5	Hour
Field Cut Tie-in	1-2	Hour
Flange Install	1	Hour

- The productivity listed above can be negatively or positively impacted by conditions, job planning, and available support.
- Continuous workflow (intraday utilization), weather conditions and size of pipe have the highest impact on efficiency and productivity (i.e., the ClickWeld® process will take longer in the winter).
- For project-specific estimates, please contact a CORE Linepipe® Sales Representative.

4.3 WEATHER CONSIDERATIONS

- The CORE Service® team will ClickWeld® and electrofuse linepipe at pipe temperatures from
- -22°F (-30°C) to +113°F (+45°C).
- Like most pipe joining systems, the ClickWeld® and electrofusion process may be challenging in severe weather conditions. Excessive dust, rain and snow must be kept clear of the ClickWeld® joining process.
- The CORE Service® team will review weather situations with the pipeline inspector. The CORE Service® team reserves the right to suspend operations if weather conditions have the potential to affect the quality of the pipe joining activities.

4.4 CORE SERVICE® KPI'S

CORE Service® aims to achieve the following KPI's:

- 100% On-time Delivery
- <4 Hour Response time - Support inquiries
- 0 TRIF/TRIR
- Minimum 1 Safety observation per day/crew
- Minimum 1 FLHA per day/crew
- >60% CORE Service® Utilization/Productive Time
- Daily efficiency reporting

4.5 CORE EFFICIENCY & INTRADAY UTILIZATION

Definitions:

- Total Hours = (travel time, safety meetings, breaks, working time)
- Working Hours = (total hours) – (travel time, safety meetings, breaks)
- Idle Time = (working hours where no CORE activities are completed)
- KPI Contributing Working Hours = (working hours) – (idle time)
 - Working hours directly related to CORE activities. ClickWeld®, cuts, tie-ins, etc.
- Intraday Utilization = (KPI contributing working hours) / (working hours)

On an average 12-hour day, 7 to 8 hours are available for KPI contributing work (ClickWeld, cuts, tie-ins, etc.). To achieve a positive and cost-effective project execution, the CORE Service team must achieve an overall project intraday utilization rate of 60% at a minimum.

4.6 HOW TO EFFICIENTLY USE CORE

- Ensure the job has the appropriate equipment and manpower loading to facilitate continuous access to work for the CORE Service® crew.
- Work with the CORE Linepipe® foreman to plan for tie-in access, HDD/BORE section construction, riser/flange installation, etc.

4.7 EXAMPLES OF HIGHLY UTILIZED & POORLY UTILIZED

Legend



Highly Utilized

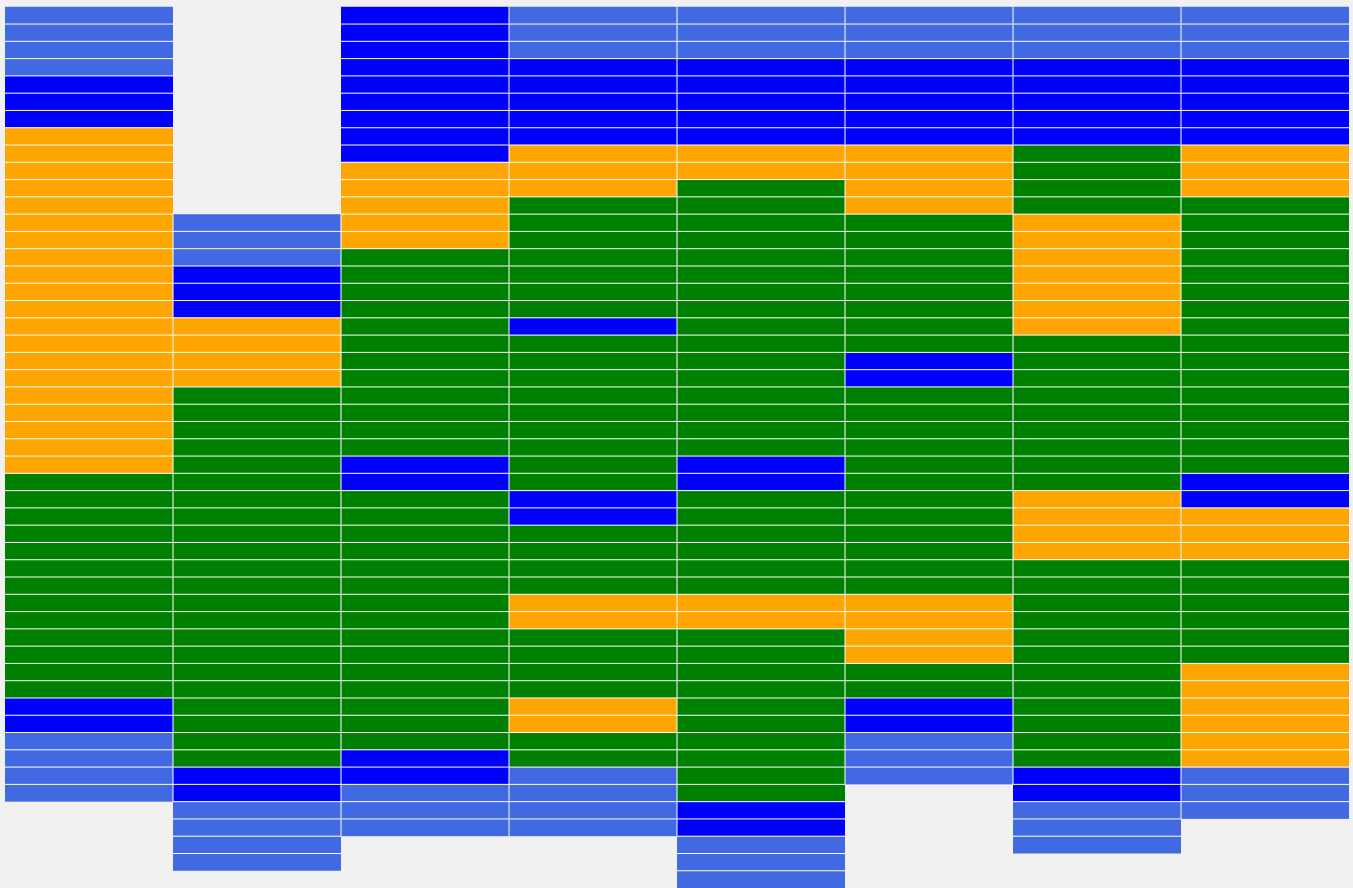

Highly Utilized

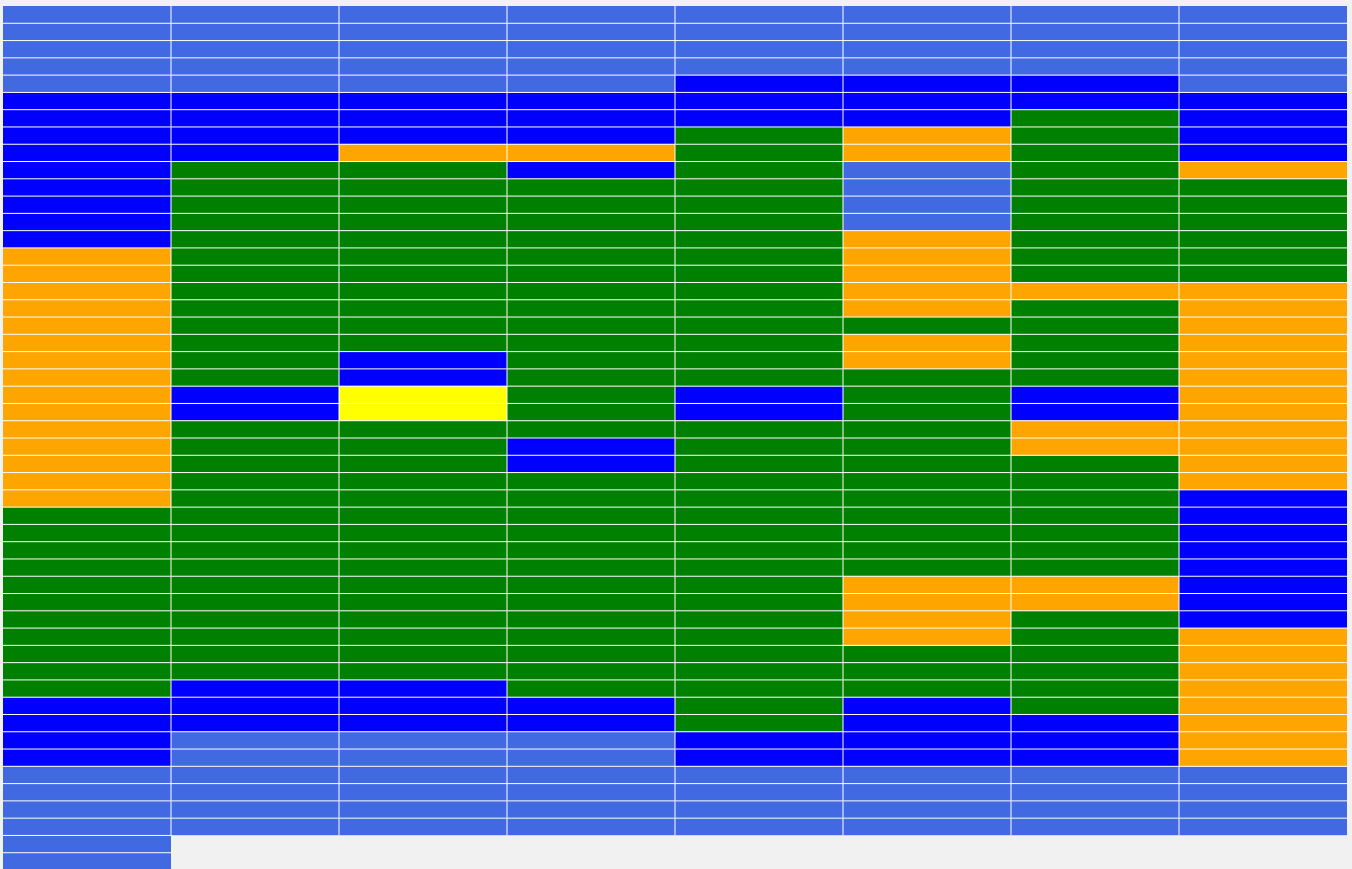

Poorly Utilized

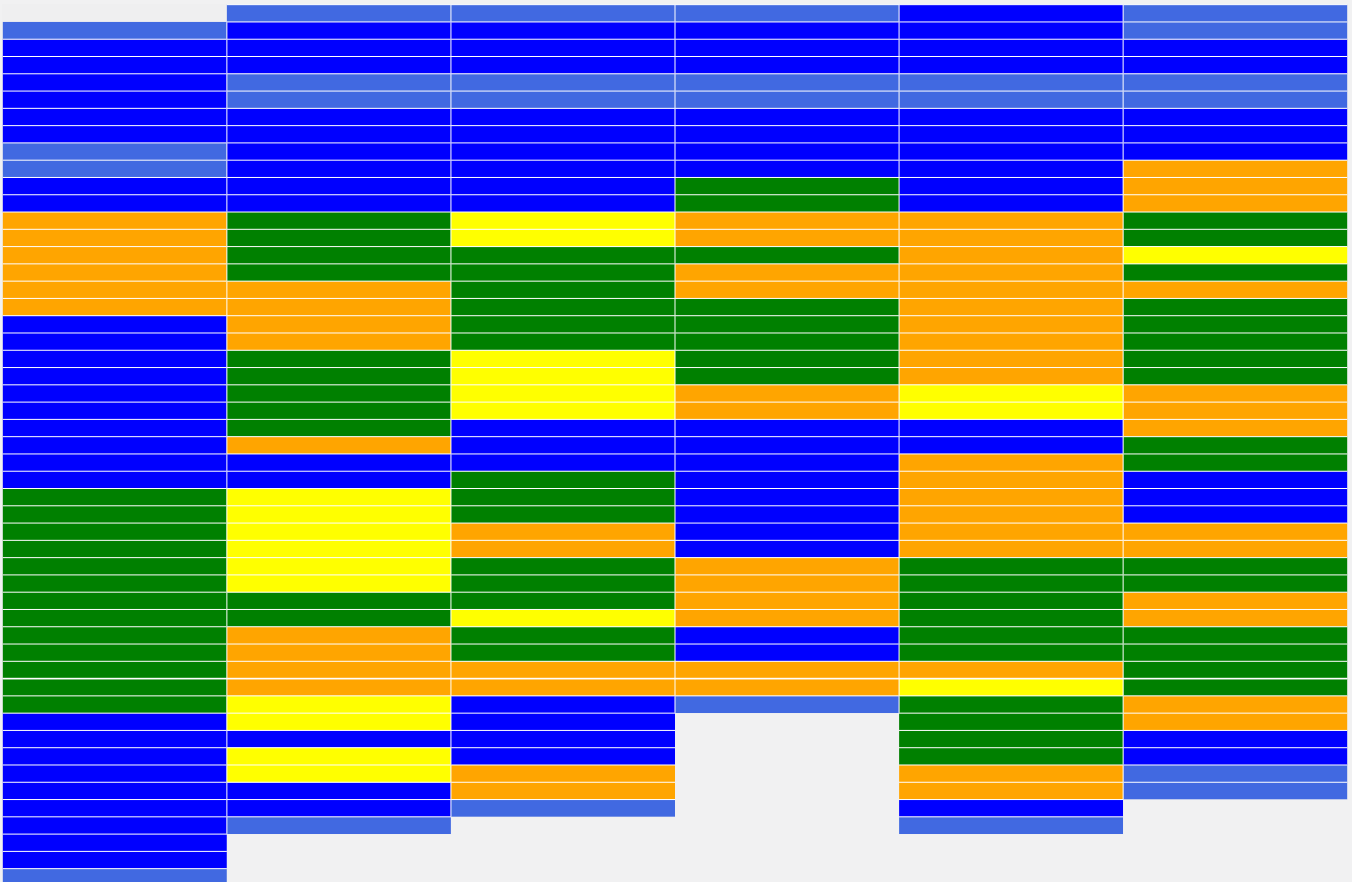

5. SETTING-UP FOR SUCCESS

5.1 PRE-JOB KICKOFF

Introduction: Within 2-3 weeks prior to shipping materials, CORE requires a pre-job kickoff meeting to collaborate and strategize with mechanical contractor to ensure project is set up for success.

The purpose of the Pre-Job Kickoff document/meeting is to coordinate on the manpower/equipment requirements, work sequence, work schedule, logistics, safety protocols, communication channels, etc.

REQUIRED MEETING ATTENDEES		
CORE Linepipe®	Pipeline Contractor	Customer/Client
Job Foreman or Superintendent	Spread Boss	Inspector

OPTIONAL MEETING ATTENDEES		
CORE Linepipe®	Pipeline Contractor	Customer/Client
Sales Representative	Management	Project Manager
	Safety/QC	Safety/QC

See [Appendix C: Pre-Job Kickoff Document](#).

5.2 RISE MODULES FOR ONSITE STAFF

Prior to starting work it is strongly recommended that the contractor put the appropriate personnel through CORE Linepipe® Rise modules.

NAME	RISE MODULES REQUIRED
Joint Coating Personnel	<ul style="list-style-type: none"> Project Execution Modules STOPAQ Application Guide
Side Boom Operator	<ul style="list-style-type: none"> Project Execution Modules ClickWeld® Mainline Field Press Remote Control
Stabber	<ul style="list-style-type: none"> Project Execution Modules ClickWeld® Mainline Field Press Remote Control Excavator Operator
Joint Prep Personnel	<ul style="list-style-type: none"> Project Execution Modules ClickWeld® Mainline Excavator Operator Field Press Remote Control Turning and Testing Scraper Repair and Maintenance Field End Prep

Field Press Operator	<ul style="list-style-type: none"> • Project Execution Modules • ClickWeld® Mainline • Excavator Operator • Field Press Remote Control
Track Hoe Operator	<ul style="list-style-type: none"> • Project Execution Modules • Field Press Remote Control • Excavator Operator
EF Technician	<ul style="list-style-type: none"> • Project Execution Modules • Field Services Electrofusion 1 • Electrofusion Basics • Plug and Seal Installation • All-Terrain Vehicles • Turning and Testing
Foreman	<ul style="list-style-type: none"> • Project Execution Modules • Electrofusion Basics • Turning and Testing • Field End Prep • Plug and Seal Installation • Field Services Electrofusion 1 • Electrofusion Crimp Recalibration • All-Terrain Vehicles • Excavator Operator • Field Press Remote Control • ClickWeld® 1 • Electrofusion 2 – Troubleshooting • Scraper Repair and Maintenance • Metallic Seal Removal
Inspector/Client	<ul style="list-style-type: none"> • Project Execution Modules
Spread Boss	<ul style="list-style-type: none"> • Project Execution Modules

Please contact a CORE Linepipe® Representative to coordinate training.

5.3 RISE MODULES FOR ESTIMATING/PROJECT MANAGEMENT

POSITION	REQUIRED RISE TRAINING
Estimator	Project Execution Modules
Client Engineer	Project Execution Modules
Inspector / Client	Project Execution Modules

Takeaways:

Estimator – To understand scope of work, required manpower, equipment, KPI's, and productivity. To gain appropriate knowledge to ensure proper alignment between CORE Linepipe®, contractor, and client; in order to achieve maximum productivity, and job efficiency.

Client Engineer – To understand what is required to complete a CORE Linepipe® project.

Inspector/Client - To understand the minimum manpower and equipment requirements to maximize productivity, quality, safety, and scope of work delineation.

5.4 EXTERNAL COATING TRAINING

The personnel involved in the external coating of CORE Liner® joints need to be trained, certified and hold a valid training certificate issued by the external coating manufacturer. The training certificate should cover the specific type of external coating and should not be older than two years.

5.5 CORE DOCUMENTATION

Relevant documents will be available upon request, incorporated into RISE Training, and located in the Appendix of this document.

5.6 SENIOR STAFF SUPPORT

CORE Linepipe® has available support for your team and projects through senior field staff. CORE Senior staff will assist with planning, job setup, stringing, tie-in planning, technical troubleshooting etc.

Project team will receive a downloadable contact sheet including CORE Linepipe® personnel.

5.7 PROJECT UPDATE & PERFORMANCE MEETINGS

CORE Linepipe® has found immense value in conducting an ongoing operations meeting throughout the duration of the project. This allows CORE Linepipe®/Contractor to address any issues or inefficiencies in real time and helps to ensure that overall success of the project.

5.8 DAILY ON-SITE PLANNING & COMMUNICATION

It is strongly recommended that the on-site leadership have a start of day and close of day planning meeting. This allows a team approach to planning for efficiency around tie-ins, crossings, bores/HDD, etc. The benefits of this include stab-on tie-ins, increased productivity and improved intraday utilization/efficiency.

Safety Communication Reminders:

- At all times, ensure positive communication is established before moving any tubulars and/or equipment.
- It is **critical** that all personnel on the job site are aware of hazards and operations.
- Always communicate to ensure we all work safely.

- If at any time, there are questions or concerns, the CORE Service® team strongly encourages you to **stop work** and discuss the issue.
- Please ensure that the pre-job Hazard Assessment is done and revisited if scope of work or conditions change.
- Any infield mobilization requirements must be communicated in advance to the CORE Service® team.

5.9 DAILY EFFICIENCY REPORTS

Transparency and accountability are paramount at CORE Linepipe®. The spirit of this report is to focus on continuous improvement and intraday utilization, cycle times, (productive vs non-productive time).

EQUIPMENT ON SITE	WEATHER: SUNNY HIGH 90S		RIGHT OF WAY COND: SANDY	
	Position	Quantity	Hours	Avg. per Hr.
W-010 - Walter Field Press				
EF-3282540 - EF-32822540	# of joints of mainline	43	6:0	7.17
TK-025 - TK-025	# Tie-in - Stab-on	0	0:0	0.00
FC-005 - Sea Container	# Tie-in - Field cut	0	0:0	0.00
	# Tie-in - Transition pup	0	0:0	0.00
	# Tie-in - Repair pup	0	0:0	0.00
	# Flange - Flange to riser	0	0:0	0.00
	# Flange - Mainline flange	0	0:0	0.00
	# Flange - Test Flange	0	0:0	0.00

12:0	TOTAL HOURS	BREAKDOWN OF DAY		
		Start time	End Time	Activity
6:0	In scope - Leads to KPI			
3:0	In scope - Doesn't lead to KPI	06:00 AM	06:30 AM	Daily activity - Travel to/from site
1:30	In scope - Travel	06:30 AM	07:00 AM	Daily activity - Tailgate/Safety
0:0	Out of scope work	07:00 AM	07:30 AM	Daily activity - Travel to/from site
1:30	Non-productive time	07:30 AM	08:00 AM	Daily activity - Day prep/end
0:0	Safety	08:00 AM	08:45 AM	Reoccurring activity - Decohesion test
		08:45 AM	09:00 AM	Mainline - Turn/Test
		09:00 AM	09:45 AM	Mainline - Clickweld
		09:45 AM	10:00 AM	Reoccurring activity - Install/Remove pullhead
		10:00 AM	12:00 PM	Mainline - Clickweld
		12:00 PM	12:30 PM	Daily activity - Lunch/breaks
		12:30 PM	12:30 PM	Mainline - Clickweld
		12:30 PM	01:00 PM	Work related - Breakdown/Repair
		01:00 PM	04:00 PM	Mainline - Clickweld
		04:00 PM	04:45 PM	Work related - Breakdown/Repair

Notes:

6. INSTALLATION PLANNING

6.1 ROW SETUP

- Prior to the material arriving on site, the pipeline contractor should complete typical ROW preparation activities (fencing, stripping, clearing, brushing etc.).
- CORE Service® teams require unrestricted access to the ROW to ensure job efficiency.
- 50 feet (15 meters) minimum ROW is required.
- Workspace required is a minimum of 21 feet (6.4 meters) from the edge of ROW to the ditch.
- Spill pile and workspace to be on opposite sides of the ditch.
- *To maximize productivity 4 feet (1.3 meters) of workspace is required on each side of CORE Liner®.

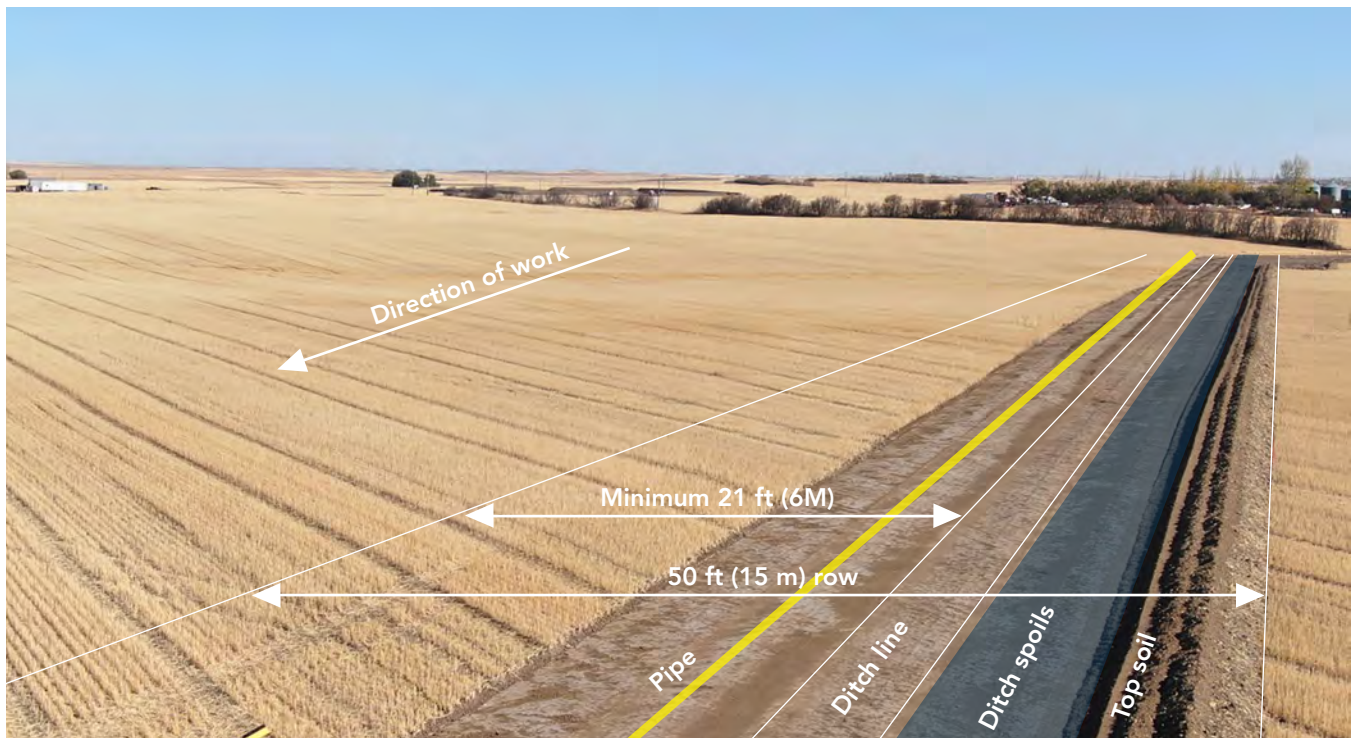

6.2 DIRECTIONAL ASSEMBLY

CORE Liner® products have dissimilar ends (factory and field end). The field end can be replicated in the field, factory end cannot.

Factory-End

Field-End Factory-End

Field-End



- Factory End - the mechanical male end of the product (alternatively described as the side of the factory installed press ring)
- Field End - the mechanical female end (alternatively described as the side of the field installed press ring).

Product orientation has a significant impact on the installation logistics, productivity, and efficiency of the job. To maximize efficiency, there is a need to properly synchronize the site layout with the direction of pipe loading, pipe stringing, workflow, crossing, boring, and tie-in directions. **Proper planning can avoid wasted time on site as well as wasted materials.**

CORE Liner® is assembled most efficiently in one direction as shown by the below ROW Layout. This is opposite to the direction of a typical pipeline workflow although CORE can be assembled in either direction. **The CORE factory end should be pointing in the direction of workflow.** (See diagram on previous page)

- The standard CORE Liner® pull head connects to the factory end of the pipeline, this is the preferred end for the HDD pull direction.

6.3 PIPE POSITION

Preferred sequencing of the ROW depends on the number of lines in the trench.

- CORE Liner® can be installed in any sequence or in- ditch position on multi-line projects
- The stringing position of CORE Liner® does not have to match the install position.
- To maximize productivity when constructing multiple lines, it is optimal to have the CORE Liner® line in the following installed positions (in the ditch)
 1. Outside position on dual line
 2. Inside position on 3 or more lines
 3. Avoid being a middle line

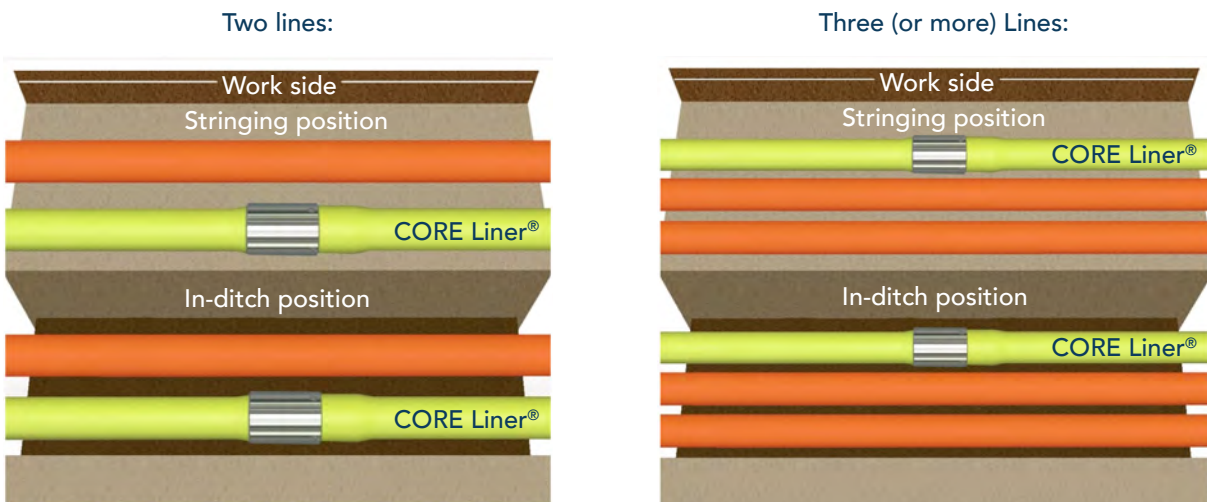

7. PIPE ON SITE

7.1 PIPE DELIVERY

CORE Liner® arrives on specially designed pipe bunks (provided by CORE Linepipe®) and can be unloaded using conventional slings, vacuum, or other approved methods. Each level of pipe is individually strapped to ensure safe delivery and stringing.

*Stringing hooks are not to be used on pipe ends. This can potentially damage the packaging, mandrel, or liner ends of the CORE Liner® system.

- Ensure appropriate lifting devices are in place according to customer's safety standards.
- Exceptional care is required to ensure that the ends of each joint of pipe are not damaged.
- Do not unpack or unwrap the ends of the CORE Liner®. Please leave this until you are directed by the CORE Service® team.
- Pipe bunks must be returned to CORE Linepipe®.
- Unreturned pipe bunks will be invoiced to the project.

CORE LINER WEIGHTS - CANADA	CL440		CL640		CL648		CL671		CL856	
	lbs	kg	lbs	kg	lbs	kg	lbs	kg	lbs	kg
Total Weight per Joint	595	270	882	400	1,011	459	1,404	637	1,586	720
Maximum Net / Payload Weight	58,000	26,332	58,000	26,332	58,000	26,332	58,000	26,332	58,000	26,332
Recommended Joints Per Truck	78		60		56		40		35	
CORE Liner® meters per truckload	1,459		1,122		1,047		748		655	

CORE LINER WEIGHTS - USA	CL440		CL640		CL648		CL671		CL856	
	lbs	kg	lbs	kg	lbs	kg	lbs	kg	lbs	kg
Total Weight per Joint	595	270	882	400	1,011	459	1,404	637	1,586	720
Maximum Net / Payload Weight	37,850	17,184	37,850	17,184	37,850	17,184	37,850	17,184	37,850	17,184
Recommended Joints Per Truck	63		42		37		26		24	
CORE Liner® feet per truckload	3,864		2,576		2,269		1,595		1,472	

7.2 PIPE STORAGE

If pipe staging is necessary, set aside a flat level area of an appropriate size. CORE Linepipe® requires different storage practices from that of bare steel. Safe and effective storage of CORE Liner® products require two main considerations over conventional steel pipe:

1. The ends of the pipe have rings that increase the diameter of the pipe. This larger diameter restricts the ability to “pyramid” stack the pipe. Spacers (pipe bunks) are required between the pipe layers to secure the pipe stack and to protect the pipe cover.
2. The ends of the pipe require keeping the packaging in place to protect the ClickWeld® components from the environment.

Follow the below steps for storing CORE Liner®:

1. Ensure the storage location has stable, level ground. Verify that the area has sufficient access for operators, lifting equipment, and pipe.
2. Clear the area of any hazards that may affect the pipe and the storage process.
3. CORE Liner® can be placed on wooden dunnage for a single level. The spacing of the dunnage should allow equipment to access the pipe and evenly support the pipe. Sufficient support under the pipe is needed to reduce cover damage. There must however be stops on the ends to prevent the pipe from rolling.
4. When stacking pipe, pipe bunks are required. Ensure the pipe maintains even contact within the bunks. Misaligned or twisted bunks put unwanted stress on the pipe cover. **CORE Linepipe® cannot be stacked without bunks. Bunks can be purchased for extra storage.**



5. Place pipe into bunks. Follow industry standards for proper lifting and moving of pipe. Start by placing pipe in the back-bunk pocket. Slow controlled movement is needed to ensure the pipe fits into the pockets and does not roll off the bunks. If available, antiroll-off equipment should be used (like a forklift on the back side). Aggressive pipe placement should be avoided to reduce pipe cover and packaging damage.
6. Place each layer of bunks above the previous bunk layer as more pipe layers are added. Avoid stacking pipe layers too high (refer to shipping table 7.1 for recommended height) as it becomes difficult to see pipe placement and causes excessive cover damage.
7. Bunks need to be returned to CORE Linepipe®. If bunks are not returned, a purchase invoice will be created. Contact a CORE Linepipe® representative should the bunks be required for long-term storage after the project has been completed.
8. Please refer to your CORE Linepipe® representative for any questions and/or support.

7.3 PIPE STRINGING

- Position the pipe as determined at the pre-job meeting (factory and field-end, directional stringing required).
- Pipe is to be strung to ensure that the factory ring (mechanical male-end) is aligned with the field end bell (mechanical female-end) of the adjacent pipe (illustrated below).

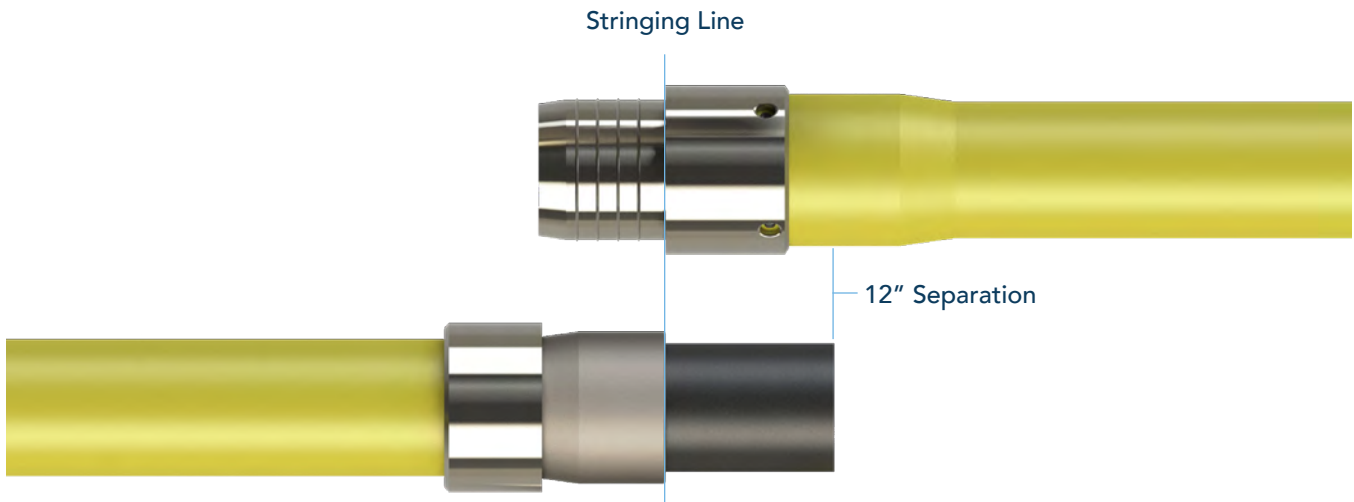

- As CORE Liner® is required to be double tubbed, plan on using twice as many pipe tubs. The tubs should be placed 11.5 feet (3.5 meters) from the pipe end. If possible, tall tubs are preferred.
- Crotches are required every 7 joints in good conditions. In poor ground conditions crotches should be utilized as frequently as is necessary to ensure pipe stability and safety.

Picture 1
Crotch with 4"×6" material



Picture 2
6" CORE Liner on a crotch



7.4 PIPE END PROTECTION

As end packaging performs a critical function in protecting ClickWeld® components, the packaging must be kept on the pipe ends up until the installation time. Prolonged storage without packaging can result in corrosion and contamination. Pipe that has been stored in the field for a long duration is subject to inspection and approval prior to installation. Removal of contamination is a critical step to ensure product quality and requires time and vigilance that typically slows down installation.

Ensure pipes in storage and pipes strung on the right of way have adequate packaging at both ends.

1. If the packaging has minor damage, repair by patching over the damaged area. Weather-resistant pipeline tape is recommended.
2. If there is no packaging on the pipe ends, or the packaging is severely damaged, the pipe ends need to be repackaged. The required material can either be procured locally or from CORE Linepipe®.
3. Basic layering of packaging consists of:
 - a. Plastic netting over steel parts: to provide an air gap between the steel and the plastic bag.
 - b. UV resistant plastic bag onto the pipe end extending over the steel onto the pipe cover: to keep out moisture.
 - c. Stretch wrap around the bag to hold it in place.
 - d. Tape around plastic bag: to seal the pipe end and secure bag.

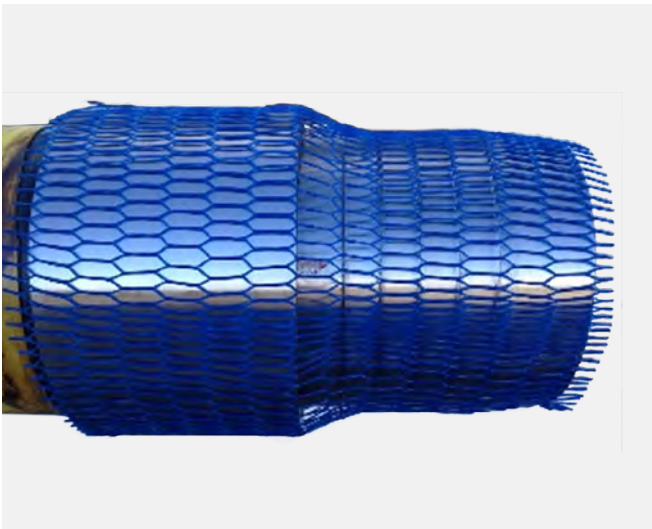

8 PIPELINE CONSTRUCTION

8.1 GENERAL MAINLINE CONSTRUCTION & PERSONNEL ALLOCATION

Mainline construction consists of 8 personnel with distinct roles as shown in the below diagram and table:

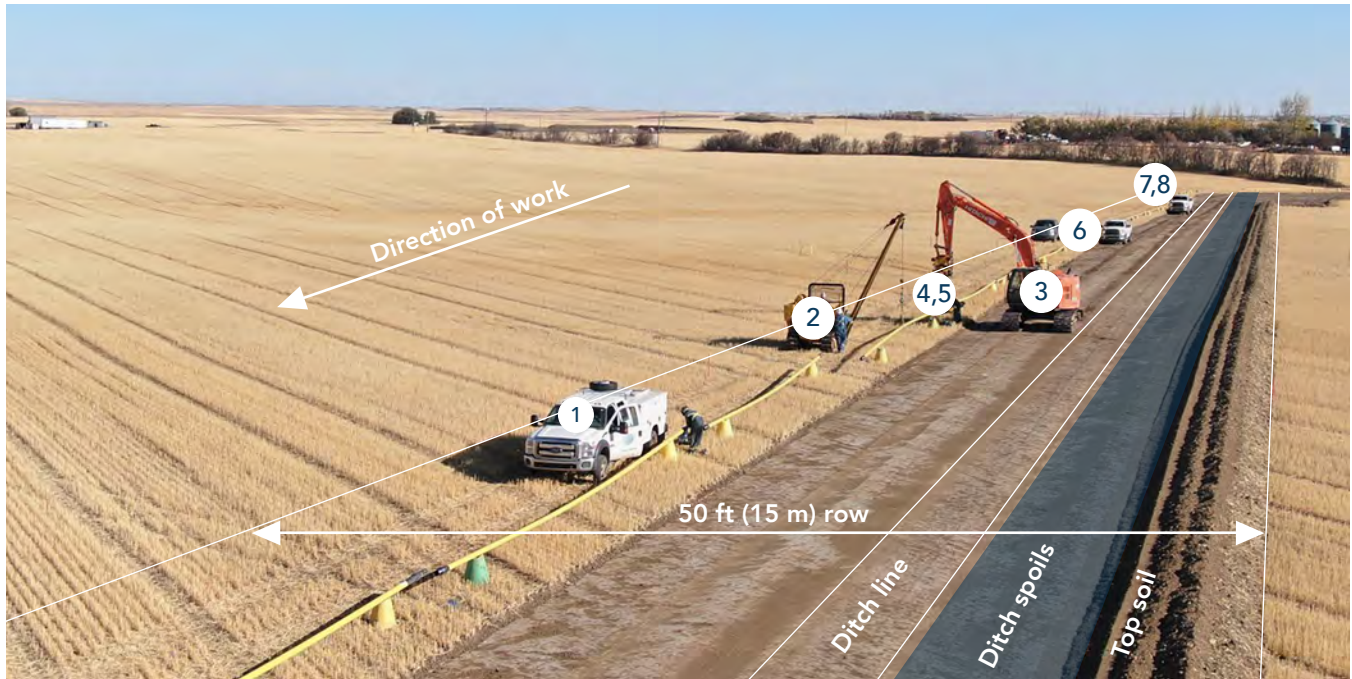

POSITION #	NAME	TASKS
1	Joint Preparation	<ul style="list-style-type: none"> Remove the end protection. Measure, cut, scrape and pre-clean the liner.
2	Side Boom Operator	<ul style="list-style-type: none"> Position the pipe to be joined.
3	Track Hoe Operator	<ul style="list-style-type: none"> Position Field Press for ClickWeld®
4	Field Press Operator	<ul style="list-style-type: none"> Clean the mandrel, EF, and the liner. Align pipe Perform the ClickWeld® Designated signal person for duration of mainline activity.
5	Stabber	<ul style="list-style-type: none"> Connect/disconnect side boom to pipe. Assist with alignment of pipe.
6	EF Technician	<ul style="list-style-type: none"> Electrofuse the liner to the EF fitting. Install the metal plugs and seals. Records all QC data.
7	Joint Coating #1	<ul style="list-style-type: none"> Install external protection after completing joint connection.
8	Joint Coating #2	<ul style="list-style-type: none"> Install external protection after completing joint connection.

8.2 MAINLINE CREW CONFIGURATION

CORE 2 – PERSON MAINLINE CONFIGURATION	
Contractor Supplied	CORE Supplied
Track Hoe	Crew/EF Truck or Side by Side
Side Boom	Job Trailer
Trucks	Field Press
Side Boom Operator	Custom Tools
Track Hoe Operator	EF Tech
Stabber	Field Press Operator
Joint Preparation	
Joint Coating #1	
Joint Coating #2	
6 Personnel	2 Personnel

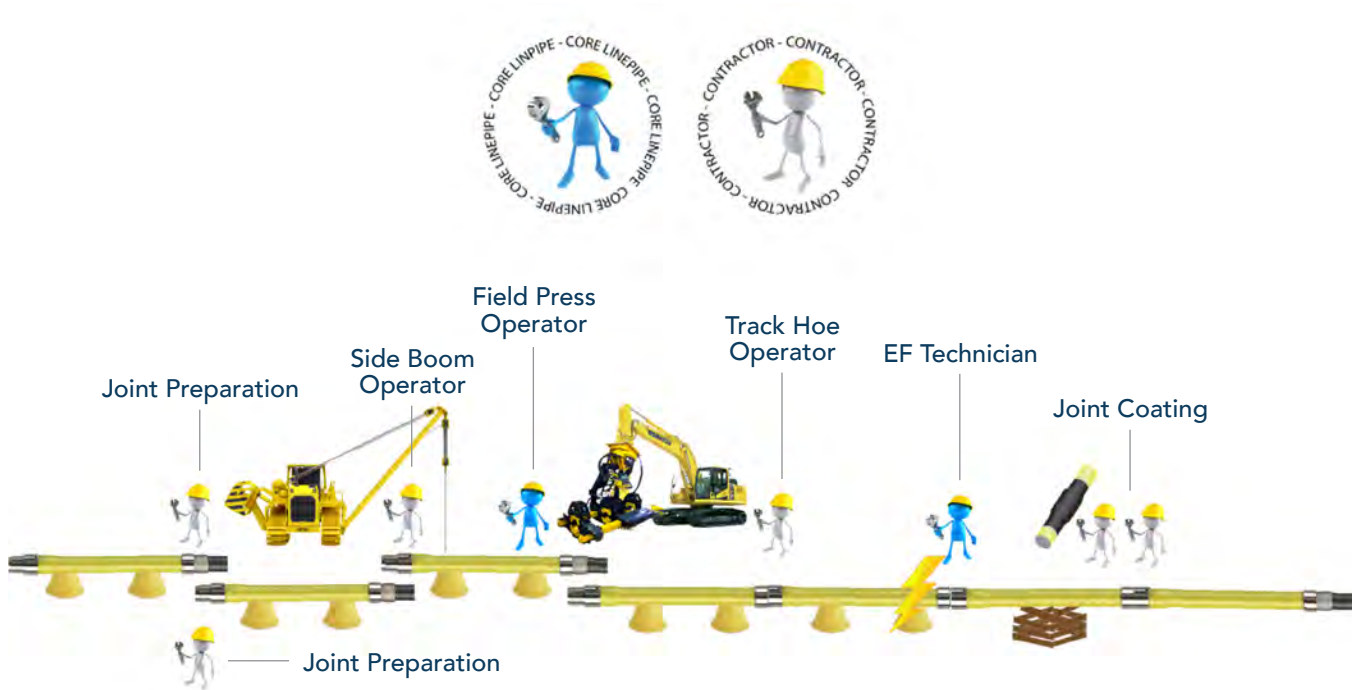

CORE 4- PERSON MAINLINE CONFIGURATION

Contractor Supplied	CORE Supplied
Side Boom	Track Hoe
Trucks	EF Truck or Side by Side
Side Boom Operator	Crew Truck
Stabber	Job Trailer
Joint Coating #1	Field Press
Joint Coating #2	Custom Tools
	Joint Preparation
	Track Hoe Operator
	EF Tech
	Field Press Operator
4 Personnel	4 Personnel

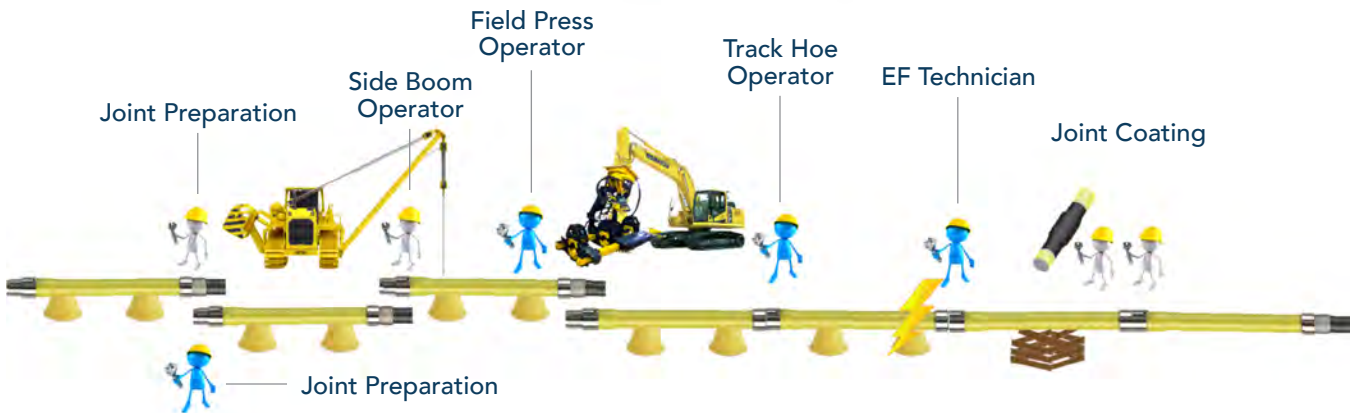

8.3 CLICKWELD®

ClickWeld® is completed using the CORE Liner® field press, working with a track hoe and side boom. This is shown in the below video.



(Video) CORE Clickweld®

8.4 ELECTROFUSION

The electrofusion technician performs the electrofusion of the liner to the EF fitting using the electrofusion processor. After electrofusing the joint, the technician installs the metal plugs and seals and records all QC information.



8.5 NIGHT CAPPING

Exposed pipe ends that are going to be left unjointed overnight, need to be repackaged (as described in section 7.4 End Protection) to prevent moisture and other contaminants/debris from entering the pipe.

If an unjointed pipe end must be left in the ditch, it must be elevated off the ditch bottom and a proper watertight end packaging must be provided by a qualified CORE Linepipe® representative. You must ensure to notify a CORE Linepipe® representative when a watertight end packaging is required.

*Failure to properly protect the CORE Liner® ends may cause damage to the product resulting in the inability to use those sticks of pipe.



8.6 ROW BENDS

- At all times ClickWeld® joints should be in straight sections of pipe, and at no time should the ClickWeld® joint be on the bent section.
- Roped bends, long sweeping bends, and drag sections react the same as conventional steel line pipe and are easily incorporated into the CORE Linepipe® system design.
- CORE Liner® must be cold bent with a minimum bend radius of 20D. CORE standard bends are with a bend radius of 20D.
- Bends can be either factory bent, or field bent.
- Bends up to 30° can be field bent using traditional bending methods and equipment.
- Bends with angles >30° are recommended to be factory bent and must be pre-ordered.
- Customer sign-off on ROW bend requirements (quantity and angle) is required prior to bending.

The cold bend radius and angle per unit length of the standard CORE Liner® ROW bends are as follows:

SIZE	TYPE	CORE LINER BEND RADIUS, D	CORE LINER BEND RADIUS, IN	DEG/FT	DEG/M
4"	Factory & field	20D	80"	8.59	28.20
6"	Factory & field	20D	120"	5.73	18.80
8"	Factory & field	20D	160"	4.30	14.10
10"	Factory & field	20D	200"	3.44	11.28
12"	Factory	20D	240"	2.86	9.40
12"	Field	40D	480"	1.43	4.70

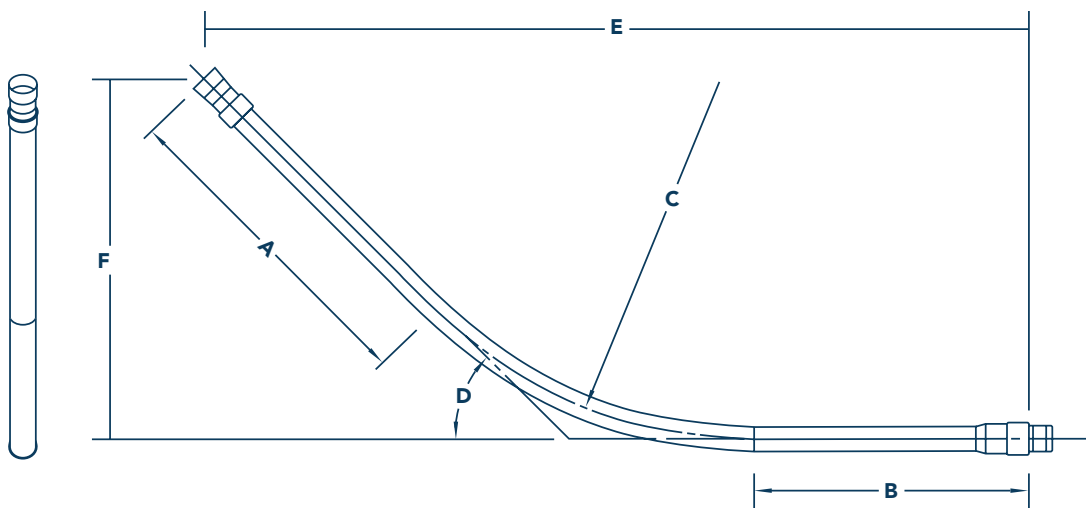

8.7 DITCH PROFILE

CORE Liner® system is most efficiently joined above grade and lowered into the ditch. For mainline sections that do not require the presence of workers in the excavation, a straight walled ditch is recommended, unless conditions require a sloped ditch for soil stability.

8.8 BELL HOLE

At risers and tie-in points where CORE Service® is working in the ditch, bell holes are required with proper ingress and egress, following industry best practices.

CORE Linepipe® requires accessible bell holes that are big enough to accommodate the installation equipment field press. Typically, a bell hole of at least 8.2 feet (2.5 meters) wide by 20 feet (6 meters) long is required.

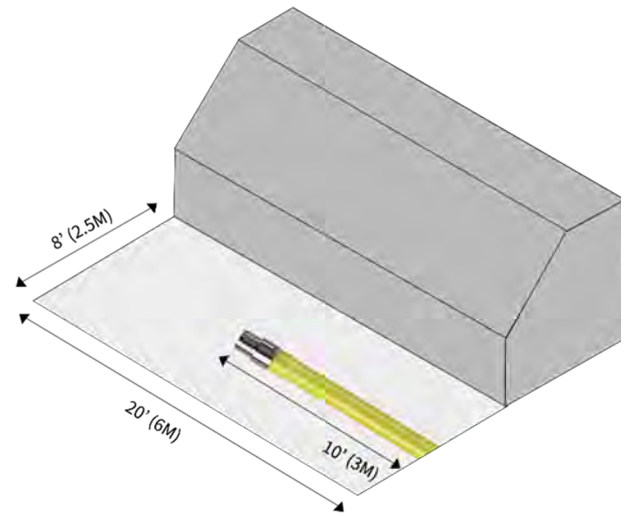

8.9 TIE-INS

- Above ground and below ground tie-ins can be accommodated.
- A minimum of 2-Lifting units are required for tie-ins.
- For in-line tie-ins, CORE Liner® requires a minimum of 3+ joint length gap starting from the joint needing connection.
- At risers and tie-in points where a CORE Service® team is working in the ditch, accessible bell holes large enough to accommodate the Field Press unit are required. Bell holes should be with proper ingress and egress, following industry safety best practices.
- Refer to bell hole requirements (8.8) section and associated drawings for below grade work.

POSITION #	NAME	TASKS
1	Joint Preparation	<ul style="list-style-type: none"> • Remove the end protection. • Measure, cut, scrape and pre-clean the liner.
2	Side Boom Operator #1	<ul style="list-style-type: none"> • Position the pipe to be joined.
3	Side Boom Operator #2	<ul style="list-style-type: none"> • Position the pipe to be joined.
4	Track Hoe Operator	<ul style="list-style-type: none"> • Position Field Press for ClickWeld®
5	Field Press Operator	<ul style="list-style-type: none"> • Clean the mandrel, EF, and the liner. • Align pipe • Perform the ClickWeld® • Designated signal person for duration of tie-in activity
6	Stabber	<ul style="list-style-type: none"> • Connect/disconnect side boom to pipe. • Assist with alignment of pipe.
7	EF Technician	<ul style="list-style-type: none"> • Electrofuse the liner to the EF fitting. • Install the metal plugs and seals. • Records all QC information
8	Joint Coating #1	<ul style="list-style-type: none"> • Install external protection after completing joint connection.
9	Joint Coating #2	<ul style="list-style-type: none"> • Install external protection after completing joint connection.



Note: Minimum of two pieces of lifting equipment are required at tie-ins (not including excavator that powers field press)Not seen in photo: Lifting equipment behind camera.

CORE 2 – PERSON TIE-IN CONFIGURATION	
Contractor Supplied	CORE Supplied
Track Hoe	Crew/EF Truck or Side by Side
Side Boom #1	Job Trailer
Side Boom #2	Field Press
Trucks	Custom Tools
Side Boom Operator	EF Tech
Side Boom Operator	Field Press Operator
Track Hoe Operator	
Stabber	
Joint Preparation	
Joint Coating #1	
Joint Coating #2	
7 Personnel	2 Personnel

CORE 4– PERSON TIE-IN CONFIGURATION	
Contractor Supplied	CORE Supplied
Side Boom #1	Track Hoe
Side Boom #2	EF Truck or Side by Side
Trucks	Job Trailer
Side Boom Operator	Field Press
Side Boom Operator	Custom Tools
Stabber	Joint Preparation
Joint Coating #1	Track Hoe Operator
Joint Coating #2	EF Tech
	Field Press Operator
5 Personnel	4 Personnel

8.10 CUSTOM LENGTH

- CORE Liner® field crews can cut pipe to custom length on location by augmenting the field-end of the CORE Liner® product. The factory-end cannot be modified.
- This allows for the field fabrication and installation of a precisely measured in-line joint or flanged end fitting. There is NO welding required in this process. No pre-ordered fixed length PUPS or special materials are required.

8.11 JOINT & REPAIR COATING

It is recommended that ClickWeld® joints are externally protected by a corrosion resistant coating. CORE Liner® products are compatible with a range of external coating options.

CORE Linepipe® recommends using STOPAQ as external corrosion protection on CORE Liner® product. CORE Linepipe® recommends using ScarGuard for mechanical protection of the STOPAQ coated joint.

CORE Linepipe® carries a stock of STOPAQ and ScarGuard and can supply it with the pipe delivery to site. Contact the CORE Liner® sales representative for further details. Refer to the Appendix for the STOPAQ/ScarGuard coating procedure.

Any holidays in the coating that are detected during the jeeeping process should be repaired using the STOPAQ material, in similar steps to what is described in the STOPAQ application procedure.

*At no point is CORE Liner to be heated beyond 130°C/266°F

STOPAQ & Scarguard Coating Procedure (See [Appendix D: External Coating Bulletin](#))

[\(Video\) STOPAQ Installation](#)



8.12 HOLIDAY DETECTION

CORE Liner® can be jeepped similar to coated carbon steel pipelines. The general jeeeping recommendations from the coating manufacturer for YJ or YJ2K coated CORE Liner® are as follows:

Product	YJ COATING		YJ2K COATING	
	Coating Thickness, mm	Voltage, V	Coating Thickness, mm	Voltage, V
CL440	0.75	7,500	1.22	12,200
CL640	0.85	8,500	1.22	12,200
CL648	0.85	8,500	1.22	12,200
CL671	0.85	8,500	1.22	12,200
CL856	1.00	10,000	1.22	12,200
CL1071	1.00	10,000	1.22	12,200
CL1279	1.25	12,500	1.22	12,200

- It is recommended not to exceed the above voltage values.
- The jeeeping voltages required at externally coated joints may be different than the voltages used for jeeeping the pipe. Ensure the appropriate voltages are applied at joint coatings and pipe coatings.
- Recommended Detector: SPY Model 785 / 790 (or equal)
- Take care to ensure the appropriate voltages are applied to external joint coating and pipe coating.

8.13 LOWERING IN

- CORE Liner® product handles very similarly to conventional line pipe.
- Only CORE approved pipe cradles (pneumatic rubber-tire) must be used as the outer diameter (“OD”) of the ClickWeld® joint is larger than the OD of the pipe (see right).
- The external coating is installed after electrofusion, plugs, and seals, but prior to lowering into the ditch.



When backfilling, follow industry best-practices to ensure the external coating is not compromised (selectively shade, no large rocks or ice clumps etc.). No special padding is required for CORE products. Review backfilling requirements with external coating supplier(s).



8.14 LINE CROSSINGS

In many scenarios, joined sections of CORE Liner® can be pulled under hotline crossings without requiring cuts or in ditch tie-ins. CORE Liner® drag sections can be treated just like conventional steel linepipe. CORE Liner® roped bends or long sweeping bends react like conventional line pipe and are easily incorporated into the CORE Liner® system design.

Crossings should be planned to have at least half a pipe length from the live line to the ClickWeld®.

Ensure the end of the drag section has appropriate protection to prevent debris and contaminants from entering the pipe.



8.15 HDD AND BORING

CORE Linepipe® products are compatible with HDD and boring scenarios.

CORE Linepipe® has developed custom pull heads to be used when pulling drag sections of CORE Liner®. The pull heads are specially designed to eliminate damage to the mandrel while providing excellent tensile pull capability.

The reusable CORE Liner® pull head can only attach to the factory end mandrel. Keep this configuration in mind when planning the directionality of a bore pull. It is possible to reverse the direction to accommodate nonconforming bore directions, but this will lead to extra work time and costs (i.e., welded pull head or transition pup).

To facilitate tie-in locations, ensure a minimum of 32.8 feet (10 meters) of pipe protrudes from the bore entry and exit.

It is recommended to hydrotest high profile pull sections prior to the pull job, according to industry best practice. Please refer to [Appendix G: Hydrotest Procedure](#).

Follow the below guidance for a successful pull job:

1. Ensure plugs, seals, ClickWeld® external corrosion protection and mechanical protection are installed prior to pulling the drag section.
2. Scar-Guard, or other protection is recommended on ClickWeld for HDD sections.
3. It is advantageous to use the CORE Linepipe® reusable pull head for pull jobs with a pull load within the CORE Linepipe® reusable pull head capability. For pull jobs with larger pull loads, welding a suitable connection to the carbon steel pipe is required.
4. CORE Linepipe® reusable pull head, steel bell cover, and mandrel sealing plug must be used to eliminate damage and debris from entering the ClickWeld® joint.
5. Precautions should be taken to protect the external coating of lined pipe if being installed into a bore casing (as per standard steel line pipe practices).

SIZE		CLICKWELD® MAX. PULL LOAD (WELDED PULL HEAD)		CLICKWELD® MAX. PULL LOAD (REUSABLE PULL HEAD)		CLICKWELD® OD		PULL HEAD ASSEMBLY OD (REUSABLE)		MIN. REAMER SIZE IN COMPRESSIBLE SOIL	
		kN	lb	kN	lb	in	mm	in	mm	in	mm
4	CL440	401	90,000	267	60,000	5.98	152	7.30	185	12	305
6	CL640	579	130,000	356	80,000	8.25	210	9.50	241	14	356
6	CL648	713	160,000	356	80,000	8.25	210	9.50	241	14	356
6	CL671	1,024	230,000	356	80,000	8.66	220	9.50	241	14	356
8	CL856	846	190,000	356	80,000	10.75	273	12.80	325	16	406
10	CL1071	1,692	380,000	-	-	13.74	349	16.24	412	22	559
12	CL1279	2,271	510,000	-	-	15.83	402	18.33	466	26	660

- Parameters listed above are based on typical bore/HDD scenarios. Please consult CORE Linepipe® for any job specific considerations.
- Consultation with HDD contractor is recommended.
- Care must be taken to ensure no dirt or contaminants enter the pipeline. Electrofusions that are contaminated with drilling fluid must be cut out. Please review with the CORE Service® team.

8.16 RISERS

- Risers are factory bent and must be pre-ordered.
- Customer sign-off on CORE Liner® dimensional riser drawings is required prior to bending.
- A minimum of two separate lifting devices (track hoe, side boom, picker) are required for installation.
- CORE Liner® risers should be supported as per industry best practices or company policy.
- Care should be taken to ensure that ditch depth and riser support options accommodate the riser dimensions.
- As-built drawings can be provided after bends are complete.

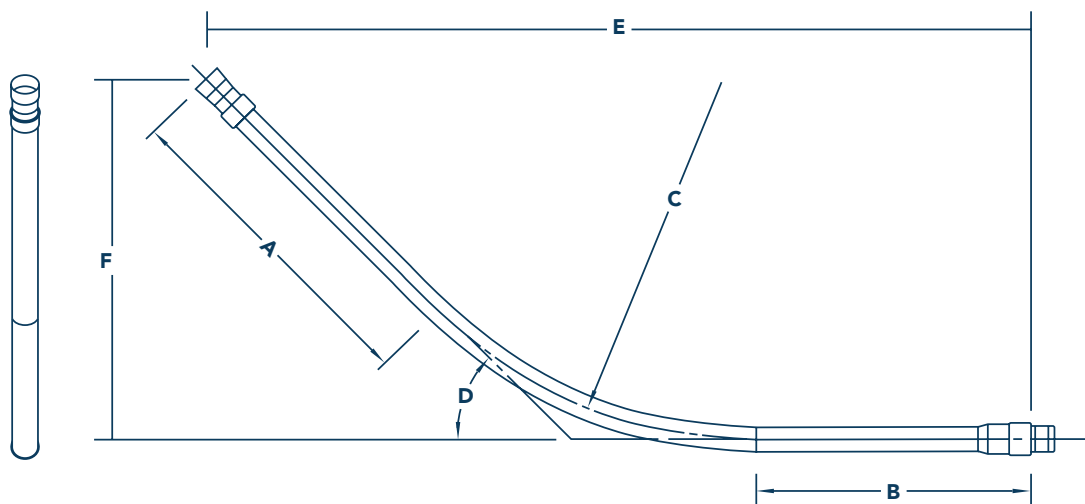

Note: D is the angle in degrees and C is the turning radius in mm or inch.

8.17 FLANGED CONNECTIONS

- CORE Liner® flanges are proprietary and unique.
- CORE Liner® flanges are ASME B16.5 raised face flanges, mounted with a ClickWeld® joint on one end and a plastic stub end on the other end.
- CORE Liner® flanges require longer studs than typical flanges.
 - Refer to [Appendix E: Flange Bolt Up Specification](#) or the stud length.
- CORE Liner® flanges require the use of carbon steel compression rings (supplied by CORE Linepipe®) to protect the plastic stub end from excessive compression. CORE Linepipe® offers several types of compression rings depending on the required service.
 - Refer to [Appendix B: Flanged End Bulletin](#) for further details.
- CORE Liner® flanged joints are to be connected as follows:
 - ClickWeld® the CORE Liner® flange to the CORE Liner® pipeline.
 - Install the CORE Liner® compression ring.
 - Install the stud bolts, nuts, and washers.
 - Tighten the bolts as per the [Appendix E: Flange Bolt Up Specification](#)
- CORE does not apply external protection to flange assemblies. For underground flanges, it is recommended that the contractor apply STOPAQ or equivalent to the flange assembly.



8.18 ANNULAR VENTS

CORE Linepipe® provides a stainless-steel vent tube, fittings, and needle valves to connect to the thread-o-let port located on each CORE Liner® flange.



8.19 BUOYANCY CONTROL

CORE products are compatible with standard industry buoyancy control systems (pipe weights).

8.20 ELECTRICAL ISOLATION

When desired, CORE Liner® flanges can be electrically isolated. Please refer to Flanged [Appendix B: Flanged End Bulletin](#) for further details (compression ring types and electrical isolation options).

8.21 CATHODIC PROTECTION

The ClickWeld® joints in CORE Liner® products are high interference fit steel-to-steel joints and as such are electrically conductive with the same amount of electrical resistance as the base pipe. As a result, CORE Liner® products are compatible with standard industry cathodic protection systems.

See [Appendix F: Exothermic Welding Bulletin](#).

9 QUALITY CONTROL

9.1 QUALITY MANAGEMENT SYSTEM

CORE's QMS is ISO 9001 certified as of November 2022.



Certificate of Registration

This certifies that the Quality Management System of

CORE Linepipe Inc.

910, 736-8th Avenue SW
Calgary, Alberta, T2P 1H4, Canada

has been assessed by NSF-ISR and found to be in conformance to the following standard(s):

ISO 9001:2015

Scope of Certification:

Engineering, design and development, sales, procurement, production, assembly, storage, and preservation of all CORE Linepipe patented products and services and field services.

A handwritten signature in black ink, appearing to read "SV".

Sameer Vachani
Senior Director, NSF-ISR

Certificate Number:	C0719761-IS1
Certificate Decision Date:	17-NOV-2022
Certificate Issue Date:	28-NOV-2022
Cycle Effective Date:	17-NOV-2022
Certificate Expiration Date*:	16-NOV-2025

Issued by:
NSF International Strategic Registrations (NSF-ISR)
789 N. Dixboro Road, Ann Arbor, MI 48105 USA

Authorized Certification and/or Accreditation Marks. This certificate is property of NSF-ISR and must be returned upon request.

*Company is audited for conformance at regular intervals. To verify certification call (888) NSF-9000 or visit our web site at www.nsf-isr.org



9.2 CLICKWELD®

The ultimate validation for CORE's ClickWeld® joints is a successful hydrotest. Prior to the CSA Z662 specified hydrotest, there are multiple quality control checks that demonstrate the robustness of the ClickWeld® joint.

- Destructive electrofusion decohesion tests are completed after every 50 fusions
- Electrofusion computer processors are calibrated on a set schedule by a qualified third-party
- Processors generate digital logs of critical parameters for each fusion
- Verification of the hydraulic load applied to push the field ring of a ClickWeld®

9.3 HYDROTEST PROCEDURE

CORE Linepipe® requires that every CORE Liner® pipeline is hydrotested after installation. The hydrotest consists of a strength test for four hours at 1.25 x design pressure, followed by a leak tightness test for four hours at 2 MPa (290 psig). Refer to the Appendix for the recommended hydrotest procedure.

See [Appendix G: Hydrotest Procedure](#).

9.4 BORE SECTION HYDROTEST PROCEDURE

CORE Linepipe® recommends that every CORE Liner® HDD/Bore section is hydrotested prior to the pull job. The hydrotest consists of a strength test for thirty minutes at 1.25 x design pressure, followed by a leak tightness test for thirty minutes at 2 MPa (290 psig). Refer to the Appendix for the recommended hydrotest procedure.

See [Appendix G: Hydrotest Procedure](#).

9.5 PIPELINE QUALITY CONTROL

CORE Linepipe® provides a complete Quality Control ("QC") package for CORE Liner® products, including material MTRs and installation data, at the end of the project. Upon special request, the MTRs can be provided separately prior to the commencement of the construction. Any other QC requirements for mechanical works are to be provided by the mechanical contractor.

10 RETURNING MATERIAL

10.1 RETURN POLICY

CORE Linepipe® makes every effort to ensure enough pipe, risers, and flanged end fittings are shipped to each pipeline project. Contingency amounts are reviewed with each customer prior to loading pipe onto trucks.

In certain cases, left-over materials remain after a project that cannot be used on subsequent projects. In these instances, CORE Linepipe® and our distributors will accept a return of materials for credit less a restocking and inspection fee in the amount of 20%.

10.2 RETURN PROCEDURE

To initiate a return, please complete a [Appendix H: Return Material Authorization \(RMA\)](#). Once submitted to the CORE Linepipe® representative, an RMA number will be issued. Please reference this RMA number when booking your unloading time at the CORE yard.

Please return pipe with the CORE Liner® packaging intact. Upon receipt at the CORE Linepipe® plant, the pipe will be inspected for damages.

APPENDIX





CORE LINEPIPE

APPENDIX A: DATA SHEET

CORE LINER[®] DATA SHEET AND OPERATING CAPABILITIES

VERSION 5.0
APRIL 21, 2023

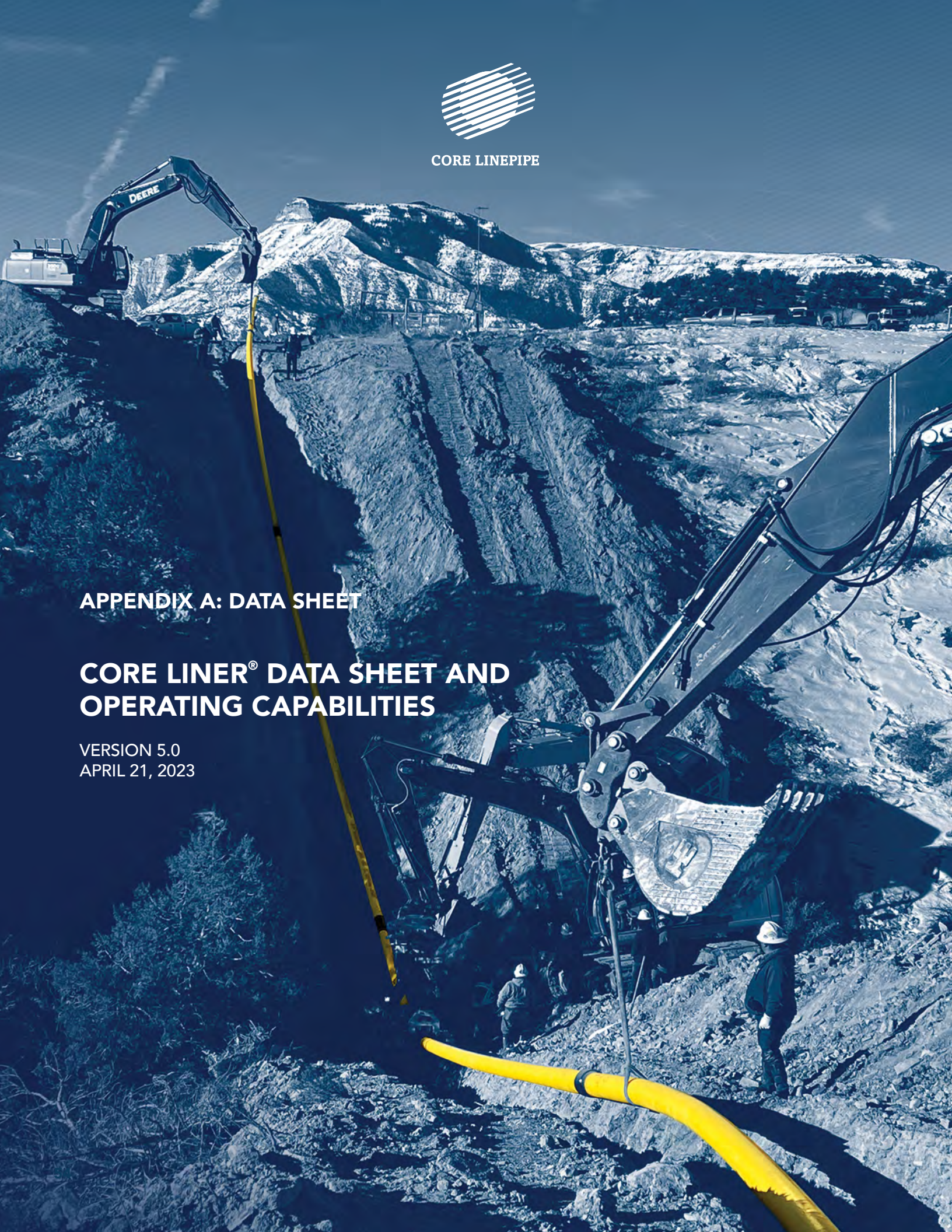

1. GENERAL

CORE Liner® is a factory built HDPE lined carbon steel pipeline system using ClickWeld® mechanical interference fit joints.

2. APPLICATION ENVELOPE

PRODUCT	MAXIMUM PRESSURE RATING		MAXIMUM TEMPERATURE RATING		WATER	OIL	GAS	SOUR
	psi	kPa	°F	°C				
CL440	2620	18,070	180°F Water/ 140°F Oil	82°C Water/ 60°C Oil				YES
CL640	1780	12,280						
CL648	2140	14,740						
CL671	3160	21,810						
CL856	1870	12,900						
CL1071*	1950	13,440						
CL1279*	1830	12,610						

Note: the product performance is dependent on actual service parameters. Consult CORE Linepipe® for a project specific evaluation. *12" will be available Q3 2023. 10" will be available Q1 2024. 10" and 12" info is subject to change.

3. DIMENSIONS

PRODUCT	STEEL OUTSIDE DIAMETER		STEEL THICKNESS		LINER INSIDE DIAMETER		LINER THICKNESS		CLICKWELD® OUTSIDE DIAMETER		PIPE WEIGHT	
	in	mm	in	mm	in	mm	in	mm	in	mm	lb/ft	kg/m
CL440	4.500	114.3	0.157	4.0	3.72	94	0.23	5.8	5.98	152	9	14
CL640	6.625	168.3	0.157	4.0	5.81	148	0.25	6.4	8.25	210	14	21
CL648	6.625	168.3	0.188	4.8	5.74	146	0.25	6.3	8.25	210	16	24
CL671	6.625	168.3	0.280	7.1	5.59	142	0.24	6.1	8.66	220	23	34
CL856	8.625	219.1	0.220	5.6	7.52	191	0.33	8.3	10.75	273	25	38
CL1071*	10.750	273.0	0.280	7.1	9.37	238	0.41	10.3	13.74	349	40	59
CL1279*	12.750	323.8	0.312	7.9	11.14	283	0.49	12.4	15.83	402	53	79

Pipe standard length is 62 ft (18.7 meters)

*12" will be available Q3 2023. 10" will be available Q1 2024. 10" and 12" info is subject to change.

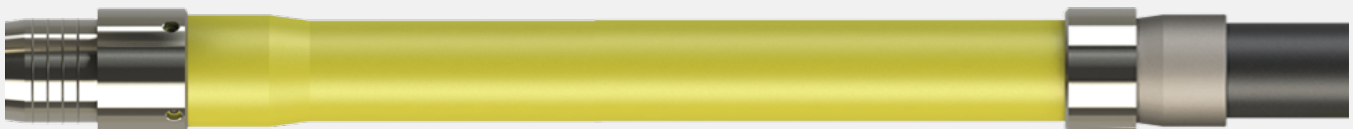

4. HYDRAULICS

PRODUCT	MAX. FLOW RATE	
	bbl/day	m ³ /day
-		
CL440	15,000	2,400
CL640	37,000	5,900
CL648	36,000	5,800
CL671	34,000	5,500
CL856	62,000	9,900
CL1071*	96,000	15,400
CL1279*	135,000	21,700

*12" will be available Q3 2023. 10" will be available Q1 2024. 10" and 12" info is subject to change.

Hazen-Williams Coefficient	150
Darcy-Weisbach Surface Roughness	0.000005 ft (0.0015 mm)
Manning	0.009
Maximum flow velocity	13 ft/s (4 m/s)

5. BORES AND HORIZONTAL DIRECTIONAL DRILLING

PRODUCT	MAXIMUM RECOMMENDED TENSILE FORCE		OD OF PULL HEAD ASSEMBLY		MIN. REAMER SIZE IN COMPRESSIBLE SOIL	
	lb	kN	in	mm	in	mm
-						
CL440	90,000	401	7.3	185	12	305
CL640	130,000	579	9.5	241	14	356
CL648	160,000	713	9.5	241	14	356
CL671	230,000	1024	9.5	241	14	356
CL856	190,000	846	12.8	325	16	406
CL1071*	380,000	1,692	16.24	412	22	559
CL1279*	510,000	2,271	18.33	466	26	660

Note: the maximum pull load for the Core Liner® pull head is 60,000 lbs for the 4" size, and 80,000 lbs for the 6" and 8" sizes. For larger pull loads, please weld a suitable connection to the pipe wall.

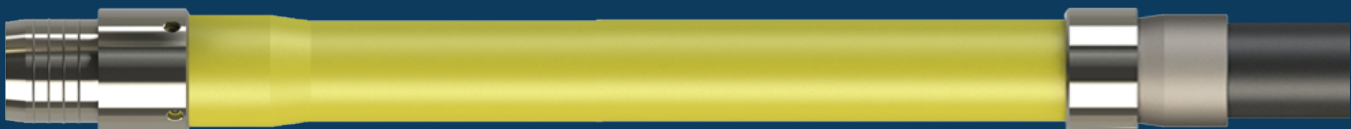

6. MATERIALS

Pipe	API spec 5L X52 PSL 2 ERW, or CSA Z245.1 Grade 359 Category II M45C SS ERW.
Flange	ASME B16.5 Raised Face with a ClickWeld® end.
	ASTM A350 LF2 class 1 for 4" ANSI 300 & 600, 6" ANSI 300 & 600, 8" ANSI 300, and 12" ANSI 600
	CSA Z245.12 Grade 359 Category II M45C Sour Service for 4" ANSI 900 & 1500, 6" ANSI 900 & 1500, 8" ANSI 600 & 900, and 12" ANSI 300 & 900
TOL	½" MSS SP-97 Class 3000 or 6000 NPT Threaded and Socket Welded, ASTM A350 LF2 Class 1
ClickWeld® Parts	API spec 5CT L80 Type 1
Bends	Shop or field cold bent pipes, minimum 20 x D bend radius. 12" field bends to be minimum 38.2 x OD
Riser	Shop or field cold bent pipes, minimum 20 x D bend radius. 12" field bent to be minimum 38.2 x OD
Liner	API 15LE bi-modal high-density polyethylene PE4710 with a minimum PENT >2000 hrs
EF Fitting	Bi-modal high-density polyethylene PE100+ with a minimum PENT >2000 hrs
Pipe Coating	Two Layer HDPE Coating up to 140°F (60°C), or Three Layer FBE with HDPE Coating up to 180°F (82°C).
Joint Protection	Field applied shrink sleeves or visco-elastic wrap

7. OPERATING CAPABILITIES

Note: The charts illustrate the product capability for each consideration alone. Please contact CORE Linepipe® for a project specific suitability evaluation for your desired combination of service parameters.

Water Service Operating Capability

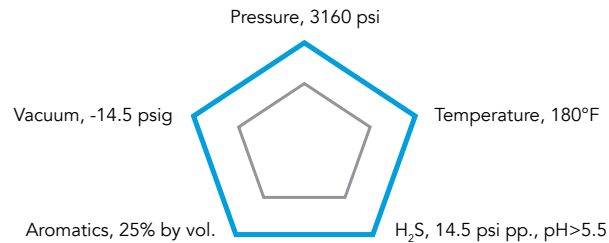

Liquid Hydrocarbons Operating Capability

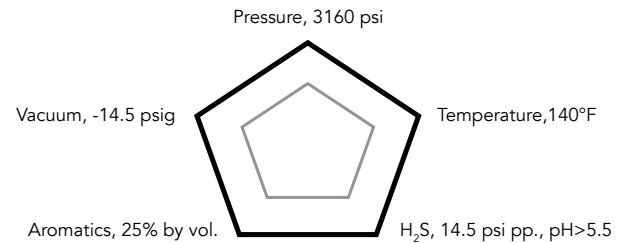

Multiphase Operating Capability

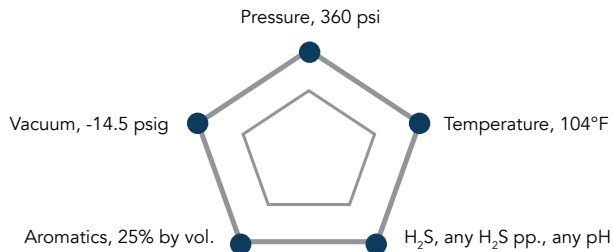

Natural Gas Operating Capability

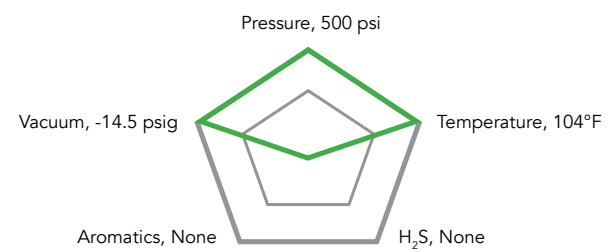

FLUID	CONDITIONS
Water	Up to the maximum pressure rating, up to 180°F (82°C)
Liquid Hydrocarbons	Up to the maximum pressure rating, up to 140°F (60°C)
Sour Liquids/multiphase	ANSI 300 service: any H ₂ S partial pressure and any pH Service up to pressure rating: H ₂ S partial pressure ≤ 14.5 psi (100 kPa) & a pH ≥ 5.5
Multiphase (with gas)	Up to 360 psi (2500 kPa), up to 104°F (40°C)
Sweet gas	Up to 500 psi (3500 kPa), up to 104°F (40°C)
Aromatics	Suitable for up to 25% aromatics up to 140°F (60°C)
Methanol	Suitable for saturated methanol up to 140°F (60°C)
Vacuum	Resistant to full vacuum (-14.5 psig or -100 kPa(g)) at 176°F (80°C) for 30 minutes*
Buckling	Liner buckling pressure of 65 psi (450 kPa) at 68°F (20°C) for a 24 hrs duration*

* SDR 25 or thicker liners

APPENDIX B: FLANGED ENDS BULLETIN

CORE Liner® Flanged Ends

I. Background

CORE Liner® is a pipe-in-pipe system that utilizes an outer steel pipe for structural strength and an inner polymer liner pipe for corrosion resistance. The outer steel pipe is joined using the proprietary Clickweld® mechanical interference fit joining system, eliminating the need for steel welding in the field. The inner polymer liner is joined using electrofusion fittings. CORE Liner® combines the strength of carbon steel and the corrosion resistance of polymers.

II. CORE Liner® Inside Surface

The inside surface of the CORE Liner® pipeline consists of a smooth polymer liner that is uniform in thickness and extends over the entire length of the pipeline from flange to flange. The liner also covers the raised face of the flange, so that only the liner is in contact with the bore fluids over the entire CORE Liner® pipeline.

III. Flange Construction

The CORE Liner® flange construction is shown below:

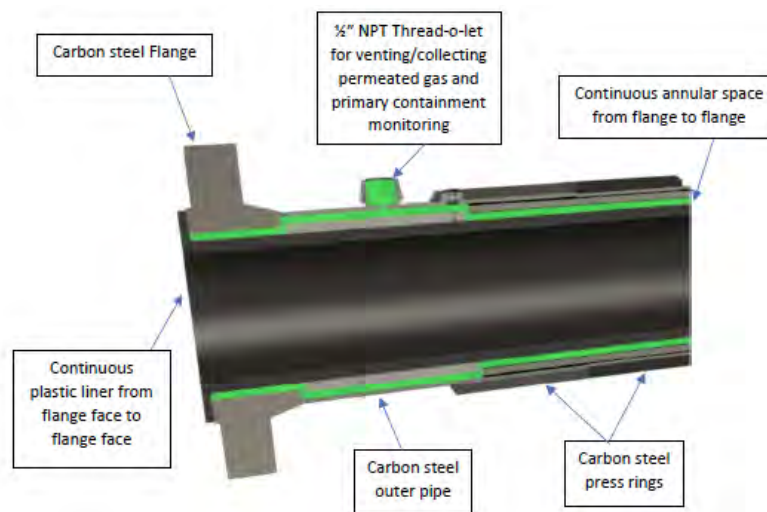

Figure 1 CORE Liner® Flange

IV. Flanged Joint Components

The flanged joint of the CORE Liner® pipeline requires the following components:

- CORE Liner® raised face steel flange along with the polymer stub end, as shown above.
- A compression ring that is used to protect the polymer stub end from excessive compression during bolt-up of the flanged joint.

V. Compression Ring Configurations

CORE Linerpipe uses three configurations of compression rings:

- A standard configuration to be generally used for ANSI 300 and 600 classes.
- A High-Performance configuration with two O-rings on one side, i.e. High-Performance compression ring SINGLE, to be used for ANSI 900 and 1500 classes, or other demanding applications, between a CORE Liner® flange and a raised face flange.
- A High-Performance configuration with two O-rings on each side, i.e. High-Performance compression ring DOUBLE, to be used for ANSI 900 and 1500 classes, or other demanding applications, between a CORE Liner® flange and another CORE Liner® flange.



Figure 2 Standard Configuration



Figure 3 High-Performance Configuration

The compression ring with the standard configuration sits between a CORE Liner® flange and an adjoining CORE Liner® or standard raised face steel flange, and does not require the use of a gasket. The compressed face of the polymer liner acts as the sealing element to ensure a leak tight connection.

The high-performance compression ring single sits directly against a CORE Liner® flange on the side of the two O-rings, and requires a gasket to seal between the back of the high-performance compression ring and the raised face of the adjoining steel flange.

The High-Performance compression ring double sits between a CORE Liner® flange and an adjoining CORE Liner® flange, and does not require the use of a gasket. The O-rings compressed against the face of the polymer liner act as the sealing element to ensure a leak tight connection.



Figure 4 Flanged joint with a standard configuration ring



Figure 5 Flanged joint with a High-Performance configuration ring

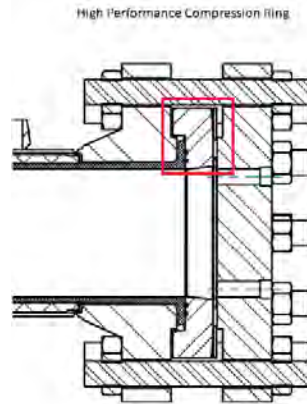
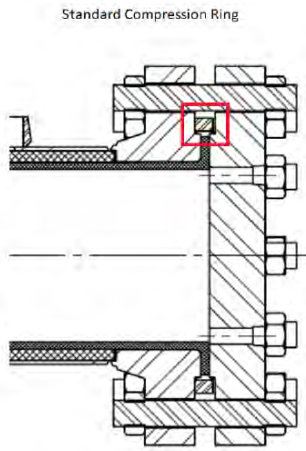

Figure 6 Flanged joint with a standard configuration ring Figure 7 Flanged joint with a High-Performance configuration ring

VI. Electrical Isolation

In corrosive applications where a carbon steel flange is connected to a metallic flange of a different material, the common industry practice is to provide electrical isolation between these two metallic flanges to avoid galvanic corrosion. In essence, electrical isolation consists of using electrically non-conductive materials to separate the carbon steel flange from the adjoining metallic flange, thus preventing electrical connectivity between the two flanges.

The electrical isolation between a CORE Liner® flange and an adjoining metallic flange depends on the configuration of the compression ring that is being used:

- For flanged joints using a standard configuration compression ring, electrical isolation requires the use of an electrically non-conductive isolation ring placed between the compression ring and the adjoining metallic flange, as shown below. The compression ring in this case is shorter than the standard compression ring, to account for the thickness of the non-conductive isolation ring.
- For flanged joints using a high-performance compression ring, electrical isolation requires the use of an electrically non-conductive gasket placed between the back of the high-performance compression ring and the adjoining metallic flange, as shown below.

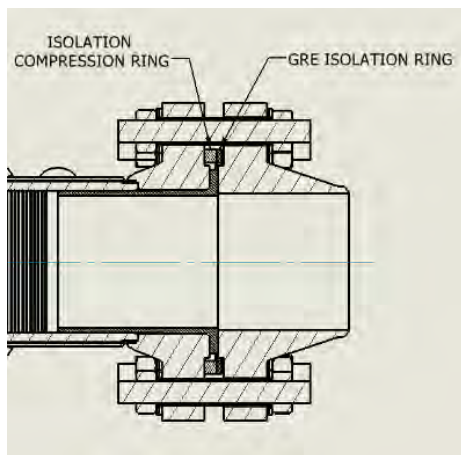

Figure 8 Electrical isolation joint with a standard configuration ring

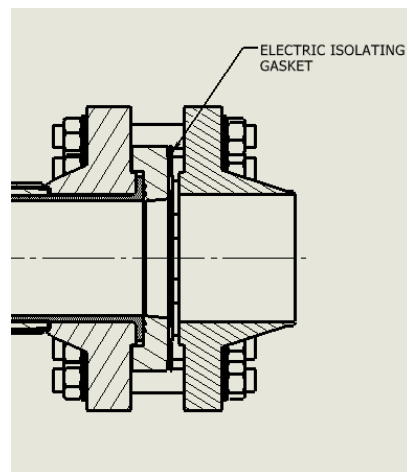

Figure 9 Electrical isolation joint with a High-Performance configuration ring

To achieve electrical isolation, all flanged joints (whether using the standard configuration or the high-performance configuration) need to use electrically non-conductive sleeves and washers for the flange studs.

VII. Compression Ring Types

For each of CL440, CL640, CL648, CL671, CL856 and CL1279, a flanged joint may use any of the following compression rings, depending on the project requirements:

#	Name	Function	ANSI 300	ANSI 600	ANSI 900	ANSI 1500
1	Standard compression ring single	Between a CORE Liner® flange and a raised face flange	Yes	Yes	-	-
2	Standard compression ring double	Between a CORE Liner® flange and a CORE Liner® flange	Yes	Yes	-	-
3	Isolation compression ring	For use in conjunction with a non-conductive isolation ring for electrical isolation between a CORE Liner® flange and a raised face flange	Yes	Yes	-	-
4	High-Performance compression ring single	For demanding applications between a CORE Liner® flange and a raised face flange	Yes	Yes	Yes	Yes
5	High-Performance compression ring double	For demanding applications between a CORE Liner® flange and a CORE Liner® flange	Yes	Yes	Yes	Yes

Notes:

1. A standard compression ring double is longer in length than a standard compression ring single.
2. A high-performance compression ring double has O-rings on both sides.
3. Electrical isolation is generally required when a CORE Liner® flange is joined to a stainless steel flange.
4. The isolation compression ring is shorter than the standard compression ring single, to account for the thickness of the non-conductive isolation ring.
5. The electrical isolation on high performance compression rings requires the use of an electrical isolation gasket between the High-Performance compression ring and the stainless steel flange. The High-Performance compression ring itself remains unchanged.
6. All electrical isolation joints, irrespective of the compression ring configuration, need to use electrically non-conductive sleeves and washers for the flange studs.



CORE LINEPIPE

APPENDIX C: PRE-JOB KICKOFF

PRE-JOB KICKOFF

VERSION 1.0 | APRIL 2023



2. PROJECT REVIEW

Review and fill out the project details, this document is intended to provide a comprehensive review of the project and should be signed and stored by all involved parties.

SCOPE REVIEW ITEM	DETAIL	
CORE Project Number		
Customer Project Number		
AFE/PO#		
Expected start Date		
CORE Estimated Construction Days:		
Product		
Survey Length		
Total Pipe Ordered		
Total Joints		
Pipe- YJ m (ft)		
Pipe- YJ Joints		
Pipe- YJ2K m (ft)		
Pipe- YJ2k Joints		
Joint Coating Requirements		
Joint Coating Certified (STOPAQ & Scarguard)		
BORE Section Lengths & Quantity		
BORE Section Lengths & Quantity		
Flanges, ANSI & Grade, Quantity		
Venting Requirements		
Isolation Kits		
Risers (Quantity)	45 degree	
	90 degree	
Riser Drawings (Approval Required)		
Factory Bends List (Approval Required)		

3. SAFETY

The safety of all stakeholders is paramount to CORE Linepipe® Leadership. Safety is embedded throughout the development of every strategy, system, process, product, and service offering. The CORE Linepipe® team takes pride in our safety culture built on:

- The engineering of safety into systems, processes, products, and equipment designs.
- Critical assessment of hazards and work procedures to ensure the safe and efficient operation by production and field personnel.
- Documentation of processes, inspections, near misses, incidents, and daily toolbox talks for training, monitoring, and compliance.

PPE requirements e.g.: FR, Hi-Vis, Monitors	
Safety tickets required?	
What orientations are required?	
Company specific rules outside the norm e.g. designated smoking areas, road rules	
Are radios required? What channels are required and does CORE need signed authority to obtain those channels?	
Toolbox/safety meeting - typically held in conjunction with the contractor.	
Permit requirements? (Daily, Weekly)	
ERP - CORE would like to have before project kick off, who can provide this to CORE?	
Is there a medic on site? Where are they located? Where is the closest hospital?	
Cell phone use: CORE requires cell phones for SiteDocs and safety paperwork	

Additional notes:

4. CREW ROTATION

The expected CORE Service® crew rotation is 24 days on and 5 days off. This is based off the current OH&S guidelines in Canada.

- For projects in the US or in other jurisdictions CORE Linepipe® can accommodate a custom crew rotation as needed.

CORE 2 – PERSON MAINLINE CONFIGURATION	
Contractor Supplied	CORE Supplied
Track Hoe	Crew/EF Truck or Side by Side
Side Boom	Job Trailer
Trucks	Field Press
Side Boom Operator	Custom Tools
Track Hoe Operator	EF Tech
Stabber	Field Press Operator
Joint Preparation	
Joint Coating #1	
Joint Coating #2	
6 Personnel	2 Personnel

CORE 4– PERSON MAINLINE CONFIGURATION	
Contractor Supplied	CORE Supplied
Side Boom	Track Hoe
Trucks	EF Truck or Side by Side
Side Boom Operator	Crew Truck
Stabber	Job Trailer
Joint Coating #1	Field Press
Joint Coating #2	Custom Tools
	Joint Preparation
	Track Hoe Operator
	EF Tech
	Field Press Operator
4 Personnel	4 Personnel

5. PROJECT LOCATION/ACCOMMODATION

Closest recommended accommodation (or camp location)

6. TICKETS & INVOICING

Who should be included on the email list for daily tickets and reports? **When sending signed tickets back please respond all.*

*There will be an upfront materials ticket that will reflect the sales order and shipping tally at the beginning of the project to accompany the daily tickets/ reports.

*All materials will be billed at the beginning of the project.

For additional items that are required to complete your project, that are not on the original order, a written request to your Sales Representative is required. Including material type, quantities, delivery instructions, financial information (AFE, project number, etc.) and billing instructions (PO update or billed on a ticket) will help to expedite deliveries.

7. SHIPPING & RECEIVING

- A minimum of 7 days notice is required to secure load time and delivery time for pipe.
 - Additional charges may apply if pipe trailers are staged or experience excessive wait time.
- Minimum 10 days notice to secure load time and delivery time for bends.
- Load times available Monday to Friday at Crossfield facility.
- No returns without appropriate completed Return Material Authorization (RMA) number and form filled out, must be approved by Gateway and CORE representative.
- All pipe bunks need to be shipped back to CORE manufacturing plant in Crossfield.
- CORE Linerpipe standard joint length is 18.7 m (62 ft).

CORE LINER WEIGHTS - CANADA	CL440		CL640		CL648		CL671		CL856	
	lbs	kg	lbs	kg	lbs	kg	lbs	kg	lbs	kg
Total Weight per Joint	595	270	882	400	1,011	459	1,404	637	1,586	720
Maximum Net / Payload Weight	58,000	26,332	58,000	26,332	58,000	26,332	58,000	26,332	58,000	26,332
Recommended Joints Per Truck	78		60		56		40		35	
CORE Liner® meters per truckload	1,459		1,122		1,047		748		655	

CORE LINER WEIGHTS - USA	CL440		CL640		CL648		CL671		CL856	
	lbs	kg	lbs	kg	lbs	kg	lbs	kg	lbs	kg
Total Weight per Joint	595	270	882	400	1,011	459	1,404	637	1,586	720
Maximum Net / Payload Weight	37,850	17,184	37,850	17,184	37,850	17,184	37,850	17,184	37,850	17,184
Recommended Joints Per Truck	63		42		37		26		24	
CORE Liner® feet per truckload	3,864		2,576		2,269		1,595		1,472	

Additional notes:

8. DELIVERY & STORAGE

- Pipe is delivered to site on wooden bunks that need to be shipped back to CORE's manufacturing plant in Crossfield.
- Synchronized pipe loading with direction for stringing. (Factory end of CORE pipe to front or rear of truck).
- There is less pipe per truck if required to be loaded mandrel to rear.
- CORE representative to be onsite for first time client, inspector, contractor (or existing contractor with a new spread boss).

9. INSTALLATION

- The installation of a CORE pipeline system is directional (during operation the pipeline can be used to transport fluids in both directions).
- Consider direction so that bores are pulled from CORE factory end (typically direction of workflow) so we can utilize CORE's reusable pull head and eliminate additional field cuts/transition pups or a welding unit to having to be on site.
- Pipe is to be double tubbed, tubs to be placed a minimum of 3.5m (11.5ft) from the end of the pipe. If possible, tall tubs are preferred. Maintain 0.3m (1ft) between pipe for front end work (cut, scrape, pre-clean).
- Pipe crotches are required at every 7 joints minimum.
- No end hooks to be used. Slings, vacuum pack or Calipers recommended.
- Spacing required for Walter between multi- lines, minimum 1.2m (4ft) on either side and 6.4m (21ft) from edge of ROW to ditch. If limited ROW 2 booms (1 in front and one behind Walter) speeds up mainline as spacing is not required on either side of CORE Liner®.

10. PACKAGING

- End packaging must remain on pipe until time of connection. Packaging that is open on pipe and is not connected must be capped at the end of each day (typically after lowering in or pre-jeep).
- Lowered in pipe must have pipe ends elevated from ditch bottom, if potential of submersion exists, end packaging needs to be waterproof.
- Submerged pipe is not recommended.
- Failure to properly protect the CORE Liner® ends may cause damage to the product resulting in the inability to use those sticks of pipe.

SCOPE REVIEW ITEM	DETAIL
Stringing/loading direction confirmed	
BORE/HDD (number, meterage, pre-test, # of boring units)	
Bore direction/Pull head requirement	

11. PIPE POSITION

- CORE Liner® can be installed in any sequence or in- ditch position on multi- line projects.
- Stringing position of CORE Liner® does not have to match the install position.
- To maximize productivity when constructing multiple lines, it is optimal to have the CORE Liner® line in the following installed positions (in the ditch).
 1. Outside position on dual line
 2. Inside position on 3 or more lines
 3. Avoid being a middle line

Additional notes:

12. BENDS & RISERS

- Riser drawing and ROW bend requirements must be signed off prior to bending.
- Bends/risers are to be pre-ordered and are subject to bend shop time availability. Average delivery is 10 days from order.
- Bends minimum of 20xD bend radius. Bends 30 degrees or greater recommended to be factory bent.
- Avoid slip bending.
- 1.82m (6ft) of straight pipe required to make a field cut.

13. MAINLINE

- Crotch required on every start/end joint and a minimum of every seven joints
- The CORE Service Team will ClickWeld® and electrofuse linepipe in ambient temperatures from -30°C (-22°F) to +45°C (+113°F).
- Productivity is affected in extreme weather conditions.

14. LOWERING IN

- Pneumatic rubber tire cradles for lowering in to eliminate cover damage.
- If regular cradles want to be used another lifting device will be required to allow cradles to pass by connections.

15. HDD & BORING

- Reference section 8.15 in Contractor Development Program for maximum pull force and hydrotest procedure.
- Reference section 8.15 in Contractor Development for Bore Hydro Test Procedure.
- The O.D. of the pipe is larger than the nominal pipe size.
- 4"-6" O.D., pull head sleeve- 7&5/ 16 O.D
- 6"-8" O.D., pull head sleeve- 9.5" O.D
- 8"-10" O.D., pull head sleeve- 12& 7/8"
- It is best practice to pre- hydrotest all high profile bore sections before pulling bores.
- CORE has a bolt on pull head that can be utilized if the pipe is strung the correct way.
- If a bore is pre-tested, a regular weld-on pull head will be required.

16. BELL HOLE & TIE IN

- Reference section 8.8 in Contractor Development for bell hole drawing.
- For in- line tie- ins, CORE Liner® requires a minimum of +3 joint length gap starting from the joint needing connections.
- CORE Linepipe® requires accessible bell holes that are big enough to accommodate the installation equipment field press. Typically, a bell hole of at least 8.2 feet (2.5 meters) wide by 20 feet (6 meters) long is required.
- Spacing required at tie-in for bore locations/ crossings (10m (1/2 joint) *(32.8ft) to be hanging out either side of bore exit/ entry. If you must cut the bore once its pulled Walter needs 3.35m (11ft) minimum from ditch wall to end of pipe.

17. SLEEVING

- It is strongly recommended that coating protection installers be certified (mandated in Canada).
- Follow supplied coating protection application guides.

18. GARBAGE DISPOSAL

- It is required for the mechanical contractor to supply an appropriate garbage disposal.
- If a factory end must be cut off, there will be a portion of secured HDPE within the steel, HDPE liner may be removed from a field end cut off.

19. ONSITE MEETING

- Schedule an onsite visit prior to stringing with inspector, contractor, and CORE field management/ foreman.

APPENDIX D: EXTERNAL COATING BULLETIN

CORE LINEPIPE® EXTERNAL COATING BULLETIN

REVISION 4.0 | APRIL 13, 2023



TABLE OF CONTENTS

1. General	04
2. Scope of Work	04
3. ClickWeld® Readiness Verification	04
4. Warning (Pipe Heating)	04
5. ClickWeld® External Coating	04
6. Holiday Detection (Jeeping)	05
7. Repairing Coating Holidays	05
8. Applying a Mechanical Protection Layer	05
APPENDIX A - ClickWeld® Readiness Criteria	06
APPENDIX B - Warning (Pipe Heating)	09
APPENDIX C - STOPAQ Application Guide	10
APPENDIX D - ScarGuard Application Guide	11
APPENDIX E - Sign-Off and Acknowledgement	12
APPENDIX F - External Coating QC Data Entry Form	13

1. GENERAL

CORE Liner® pipelines are intended as corrosion resistant pipelines. CORE Liner® pipes are generally delivered to the field with an external coating. To maintain the external corrosion resistance of the CORE Liner® pipeline, it is strongly recommended that an external corrosion resistant coating is applied to the ClickWeld® joints, after the field joining process is completed.

2. SCOPE OF WORK

CORE Linepipe® carries a stock of joint coating materials and can supply it with the pipe delivery to site, if requested by the client/contractor. Please contact a CORE Linepipe® sales representative for further details.

All tools, consumables and ancillaries required for the external coating application are to be supplied by the external coating applicator (the contractor).

3. CLICKWELD® READINESS VERIFICATION

ClickWeld® and electrofusion joints must be complete, which includes installed inserts and plugs, before a ClickWeld® joint is ready to be externally coated. Please ensure that the ClickWeld® joint is fully completed prior to applying the external coating. To verify that the ClickWeld® joint is completed and ready to be externally coated, please refer to [APPENDIX A](#) for the ClickWeld® readiness criteria.

4. WARNING (PIPE HEATING)

CORE Liner® is susceptible to damage by heating as it has a polyethylene liner inside the pipeline. Overheating CORE Liner® can potentially lead to damage, failure, and costly repairs. Please refer to [APPENDIX B](#) for warning notes regarding heating.

5. CLICKWELD® EXTERNAL COATING

Although many external coatings are suitable for use on CORE Liner® pipelines, CORE Linepipe® recommends using STOPAQ as external corrosion protection on CORE Liner® joints. Nevertheless, CORE Linepipe® clients may elect to use other external coatings. Please contact a CORE Linepipe® sales representative for confirmation of suitability, guidance and training recommendations for your coating of choice.

PRODUCT	APPLICATION
STOPAQ WRAPPINGBAND CZ	OPERATING TEMPERATURE UP TO 50°C (122°F)
STOPAQ WRAPPINGBAND CZH	OPERATING TEMPERATURE UP TO 70°C (158°F)
STOPAQ WRAPPINGBAND CZHT	OPERATING TEMPERATURE UP TO 85°C (185°F)
STOPAQ OUTERWRAP PE	OPERATING TEMPERATURE UP TO 70°C (158°F)
STOPAQ OUTERWRAP HTTP	OPERATING TEMPERATURE UP TO 85°C (185°F)

The application procedure for the STOPAQ material on ClickWeld® joints is detailed in [Wrappingband and Outerwrap for CORE Linepipe ClickWeld Application](#) and is included in [APPENDIX C](#).

All personnel involved in applying external coatings on CORE Linepipe® products must be trained by a representative of the external coating manufacturer. It is strongly recommended that all personnel involved in applying external coatings on CORE Linepipe® products complete the CORE Linepipe® external coating online information module.

TOTAL MAXIMUM ROLLS PER CLICKWELD (STOPAQ)					
STOPAQ PRODUCT	4 INCH	6 INCH	8 INCH	10 INCH	12 INCH
WRAPPINGBAND 100MM/4"	0.65	0.51	0.70	1.02	1.40
WRAPPINGBAND 50MM/2"	0.12	0.29	0.40	0.58	0.80
OUTERWRAP 75MM/3"	0.54	0.45	0.56	0.90	1.12
OUTERWRAP HTPP 100MM/4"	0.25	0.33	0.41	0.66	0.82

TOTAL MAXIMUM ROLLS PER CLICKWELD (SCARGAURD)					
SCARGUARD PRODUCT	4 INCH	6 INCH	8 INCH	10 INCH	12 INCH
SCARGUARD 6" x 30' ROLL	1	1	1	1.5	2

6. HOLIDAY DETECTION (JEEPING)

Holiday detection and jeeping is the responsibility of the pipeline contractor. CORE Liner® pipes can be jeeped similar to coated carbon steel pipelines. The coating manufacturer general recommendations for jeeping YJ or YJ2K coated CORE Liner® pipes are as follows:

PRODUCT	YJ COATING		YJ2K COATING	
	COATING THICKNESS, MM	VOLTAGE, V	COATING THICKNESS, MM	VOLTAGE, V
CL440	0.75	7,500	1.22	12,200
CL640	0.85	8,500	1.22	12,200
CL648	0.85	8,500	1.22	12,200
CL671	0.85	8,500	1.22	12,200
CL856	1.00	10,000	1.22	12,200
CL1071	1.00	10,000	1.22	12,200
CL1279	1.25	12,500	1.22	12,200

- It is recommended not to exceed the above voltage values and to use detectors SPY Model 785 / 790 (or equal).
- The jeeping voltages required at externally coated joints may be different than the voltages used for jeeping the pipe. Ensure the appropriate voltages are applied at joint coatings and pipe coatings.
- Holiday testing of the STOPAQ coating requires a voltage of 15,000 volts. Please refer to the STOPAQ Application Guide in [APPENDIX C](#) for further guidance on jeeping STOPAQ coatings.

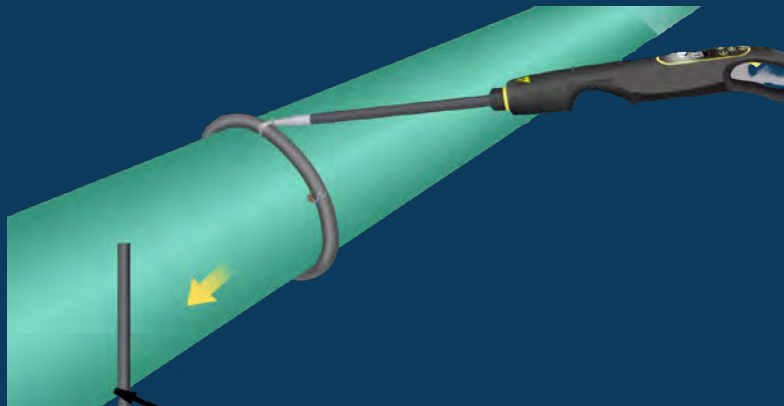

7. REPAIRING COATING HOLIDAYS

Any holidays in the coating that are detected during the jeeeping process should be repaired using the STOPAQ material, in similar steps to what is described in the STOPAQ application procedure.

8. APPLYING A MECHANICAL PROTECTION LAYER

For bores and HDD applications, CORE Linepipe® recommends using ScarGuard for mechanical protection of the STOPAQ coated ClickWeld® joints. The ScarGuard application procedure is detailed in [APPENDIX D](#).

APPENDIX A - CLICKWELD® READINESS CRITERIA

COMPLETED CLICKWELD® - READY FOR EXTERNAL COATING

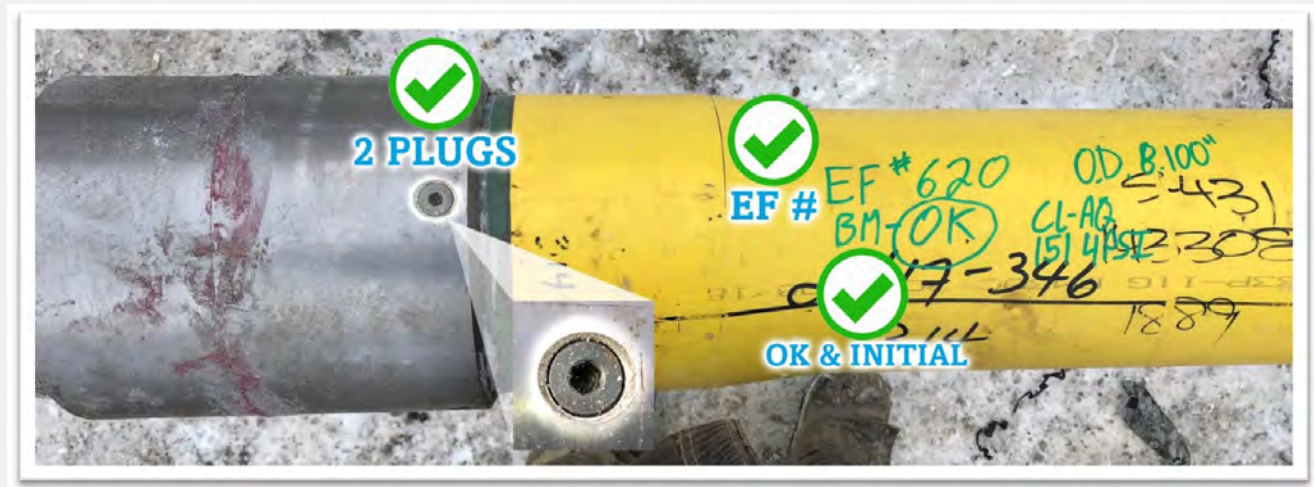

Check for ALL of the following prior to applying external coating:

1. Both plugs are installed
2. EF # is written
3. OK and initials are present

There is only one acceptable scenario that indicates a ClickWeld® joint is ready to be externally coated. The above image shows the requirement of the EF #, two installed plugs, and an ok with initials.

IF ANY OF THESE THREE ARE MISSING, DO NOT EXTERNALLY COAT!

Contact a CORE Service® team member before moving forward.

INCOMPLETE CLICKWELD® - DO NOT COAT

Scenario 1: No plugs



Even if there is an EF # and an OK and initial, if both plugs are not installed, external coating should not be applied.

DO NOT EXTERNALLY COAT IF A PLUG IS MISSING!

Scenario 2: No EF#

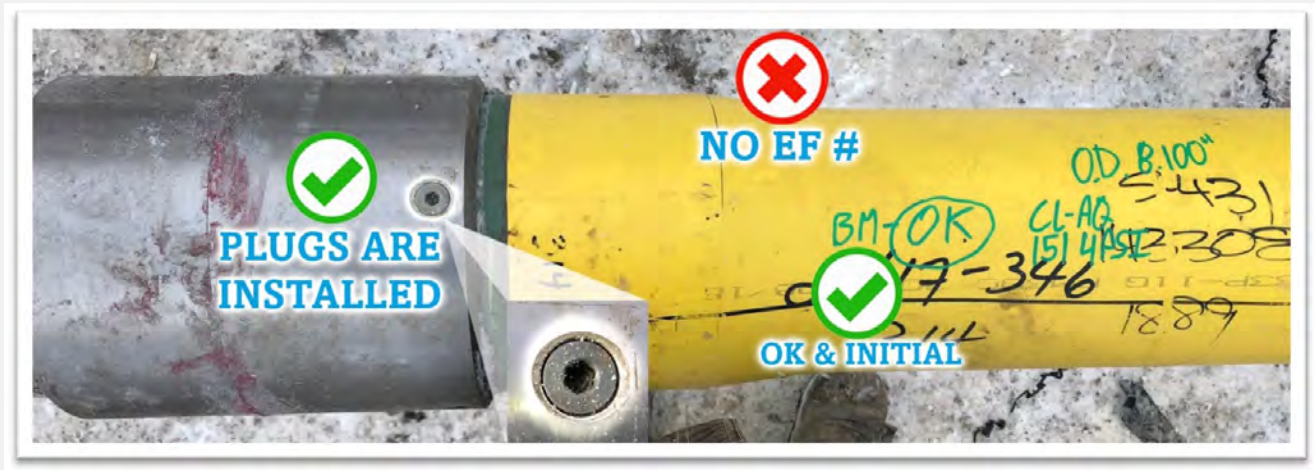

Even if there is an OK and initial and both plugs are installed, if there is no EF #, the joint should not be externally coated.

DO NOT EXTERNALLY COAT IF "EF #" IS MISSING!

Incomplete ClickWeld® - DO NOT COAT

Scenario 3: No "OK" and Initial



Even if both plugs are installed and there is an EF #, if there is no OK and initial, the joint should not be externally coated.

DO NOT EXTERNALLY COAT IF "OK" AND INITIAL IS MISSING!

APPENDIX B - WARNING (PIPE HEATING)

1. CORE Liner® must not be overheated from the installation of the external coating. CORE Liner® has a polyethylene liner inside the pipeline. Damage/failure of the liner could occur as a result of overheating. Liner damage/failure is not visible from the outside of the pipeline. Overheat scenarios could require costly repairs.
2. The temperature of the entire surface to be coated shall be measured using a calibrated digital surface contact thermometer. The surface temperature must be measured frequently to promptly detect when the required temperature is reached. When measuring the temperature, allow the digital surface contact thermometer to touch the surface for at least three seconds (and until the temperature reading stabilizes) before taking the temperature reading.
3. Contact your CORE Linepipe® foreman for any questions or clarifications.
4. All personnel involved in applying external coatings on CORE Linepipe® products must sign the Sign-Off and Acknowledgement of CORE Linepipe® External Coating Requirements sheet. Refer to [APPENDIX E](#).
5. The CORE Liner® pipe should never be heated to a surface temperature above the following:

PRODUCT	MAXIMUM ALLOWABLE TEMPERATURE
CL440	85°C (185°F)
CL640 CL648, CL671, CL856	130°C (266°F)

If this temperature is ever exceeded, you must contact a CORE Linepipe® representative immediately. The joint will be inspected and the damaged section will be replaced.

6. The warning sticker (shown below) is to be removed from on the pipe after the external coating is applied and prior to jeeeping.

CL640 CL671
CL648 CL856

WARNING



DO NOT OVERHEAT THE PIPE.
OVERHEATING WILL DAMAGE THE PLASTIC LINER.

TO REMOVE THE DEW, THE SURFACE OF THE JOINT ONLY REQUIRES TO BE HEATED
3°C (5°F) ABOVE DEW POINT.

DO NOT EXCEED 266°F/130°C SURFACE TEMPERATURE AT ANY TIME DURING COATING.

EXTERNAL COATING TO ONLY BE APPLIED BY TRAINED TECHNICIANS.
REFER TO CORE LINEPIPE EXTERNAL COATING BULLETIN.

CONTACT CORE LINEPIPE FOREMAN FOR PROJECT SPECIFIC INSTRUCTIONS. R05

CL440

WARNING



DO NOT OVERHEAT THE PIPE.
OVERHEATING WILL DAMAGE THE PLASTIC LINER.

TO REMOVE THE DEW, THE SURFACE OF THE JOINT ONLY REQUIRES TO BE HEATED
3°C (5°F) ABOVE DEW POINT.

DO NOT EXCEED 185°F/85°C SURFACE TEMPERATURE AT ANY TIME DURING COATING.

EXTERNAL COATING TO ONLY BE APPLIED BY TRAINED TECHNICIANS.
REFER TO CORE LINEPIPE EXTERNAL COATING BULLETIN.

CONTACT CORE LINEPIPE FOREMAN FOR PROJECT SPECIFIC INSTRUCTIONS. R05

APPENDIX C
STOPAQ APPLICATION GUIDE

STOPAQ® Wrappingband is a corrosion preventing material adhering extremely well to steel and factory applied pipeline coatings like PE, PP and FBE. **STOPAQ® Outerwrap** is used for the mechanical protection of Wrappingband. The heavy-duty Outerwrap provides resistance to impacts, indentations and abrasion, and is also resistant to chemicals like alkalis and acids. Both materials are supplied in a rolled format. For a CORE Linepipe ClickWeld application, the below sizing is used:

Wrappingband CZ/CZH/CZHT

100mm x 10m (3.94" x 32.81') and 50mm x 10m (1.97" x 32.81')

Outerwrap PE/PVC/HPPP

75mm x 30m (2.95" x 98.43')



STOPAQ VIDEOS

▶ STOPAQ ClickWeld
Application

Training – It is required that field personnel applying the STOPAQ® coating to CORE Liner® products are trained by a representative of the STOPAQ® supplier.

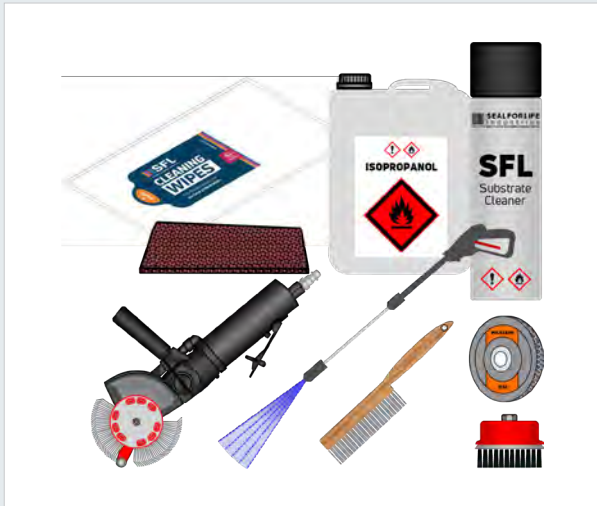

1. Equipment List

- Temperature probe, dew point tester, high voltage holiday tester, solvent cleaner
- Appropriate tools for surface preparation, wire brush, 60–80 grit sand paper, abrasive blasting pot (optional), appropriate abrasive media (optional)
- Scissors, knife, measuring tape, clean lint free rags, Standard safety equipment such as gloves, goggles, hard hat, etc. Check SDS for specific PPE.

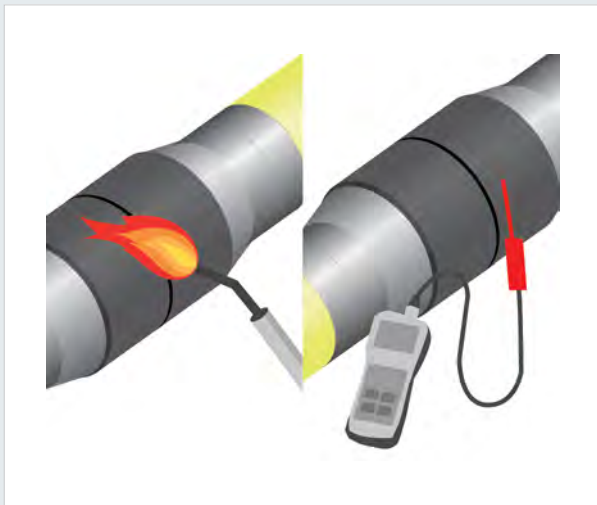

2. Heating

Excessive heat can damage the internal plastic liner of the CORE Liner® product and may lead to a pipeline failure. Bare pipe sections of the CORE Liner® product are particularly susceptible to heat damage, as the plastic liner in those locations is only protected by a thin bare pipe. This is particularly relevant to the CL440 product.

STOPAQ® is intended for cold application without the use of heat. Significant pipe heating typical of shrink sleeve applications is not required for STOPAQ®. Only removing the dew from the pipe surface, if present, is needed for the application of STOPAQ®. If dew is not present, no heat application is required.

Removing the dew, where dew is present, only requires a minimal amount of heat. To remove the dew, use a tiger torch on a low setting for between 10 – 20 seconds in a continuous uniform movement along and around the surface to be coated. Target a surface temperature of 3° Celsius (5° Fahrenheit) above the local dew point temperature.

Promptly check the temperature of the entire surface to be coated using a contact surface thermometer. Temperature guns may give misleading results and are not to be used. Record the measured temperature and the ClickWeld® joint number on the project register.

Product	Max Allowable Temp
CL440	85° Celsius (185° Fahrenheit)
CL640, CL648, CL671, CL856	130° Celsius (265° Fahrenheit)

The internal plastic liner of any section where the temperature exceeded the maximum allowable temperature of the above table may have been heat damaged. Cut that section out and replace it with a new pipe section. Where heating is needed, heat every ClickWeld® joint separately and apply the STOPAQ® coating immediately after heating that pipe section. Avoid re-heating a pipe section as the heat build-up can be significant, and may lead to damaging the internal plastic liner. If the pipe is heated and not immediately coated, allow for sufficient time for the heated section to fully cool down before re-heating it. Pre-heat the STOPAQ® tape separately and keep it in a warm/protected place until it is applied on the pipe section for ease of application.



3. Surface Preparation

The surface of the ClickWeld fitting is required to be cleaned prior to the application of STOPAQ® products. The surface shall be cleaned to a minimum SSPC / NACE SP3, ISO 8501 St2 / St3 (Hand / Power tool cleaning). Lightly abrade the mainline coating 50mm (2") adjacent to the cutback area.

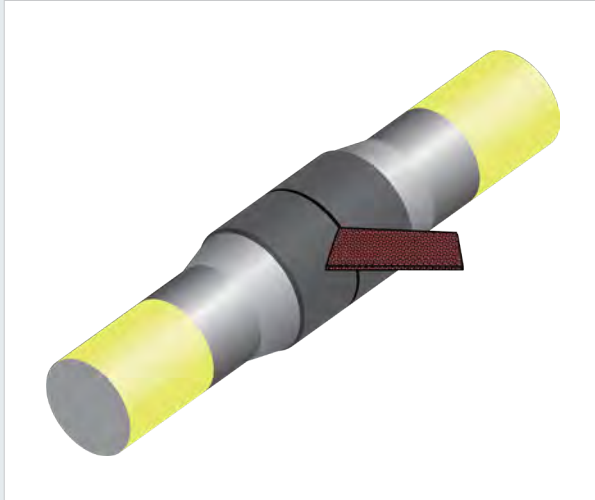

4. Solvent Cleaning After Preparation

Degrease and wipe clean the steel and coated areas to remove foreign materials using a solvent wipe.

Approved Solvents

- *Isopropanol ≥95% (recommended solvent for STOPAQ products)*
- *Any solvent that flashes off 100% without leaving a residue*

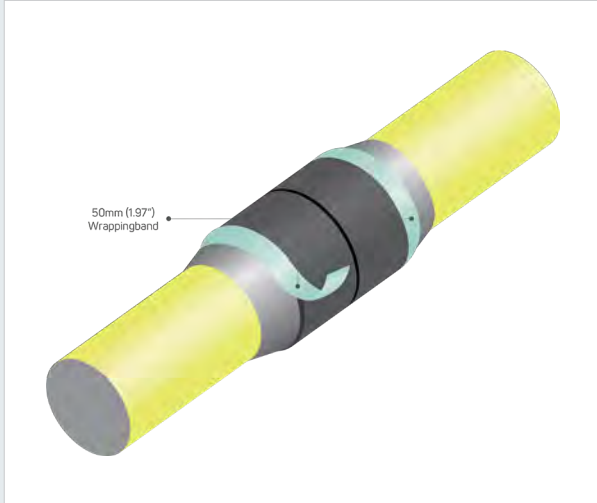

5. Coat ClickWeld Transition

Cut strips of 50mm x 10m (1.97" x 32.81') Wrappingband. Remove the release liner and apply to either side of the ClickWeld joint until transition is filled. Multiple wraps may be required.

- CL 440** 2 strips 53cm (21")
- CL 640** 2 strips 71cm (28")
- CL 648** 2 Strips 71cm (28")
- CL 671** 4 strips 74cm (30")
- CL 856** 4 strips 91cm (36")

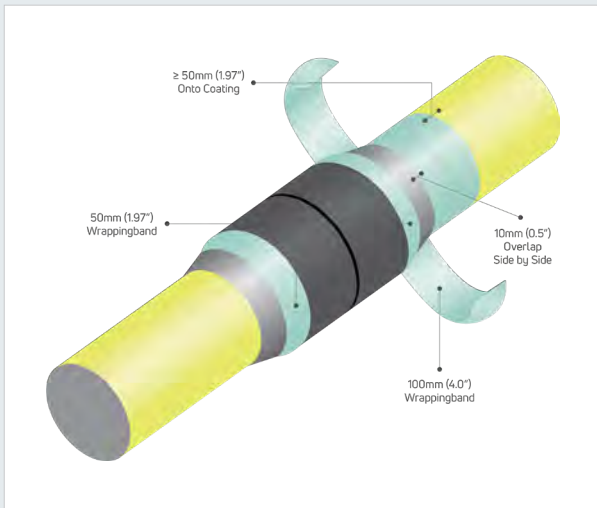

6. STOPAQ® Wrappingband Application 1

Cut a number of strips of 100mm x 10m (3.94" x 32.81') Wrappingband according to the appropriate ClickWeld fitting.

- CL 440** 11 strips 53cm (21")
- CL 640** 7 strips 71cm (28")
- CL 648** 7 strips 71cm (28")
- CL 671** 7 strips 74cm (30")
- CL 856** 7 strips 91cm (36")

Remove the release liner on the first strip and start by applying the Wrappingband with a ≥ 50 mm [2"] overlap onto the mainline/plant coating. Apply Wrappingband without any tension onto the substrate with a ≥ 50 mm [2"] circumferential wrap onto itself. The print string on the Wrappingband should be facing the application direction. Avoid air-enclosures.

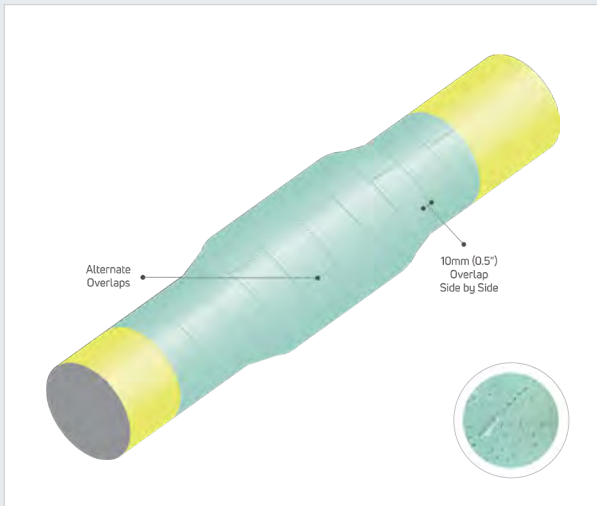

7. STOPAQ® Wrappingband Application 2

Continue to apply the additional Wrappingband strips successively alternating their starting positions. Install each subsequent strip with a minimum 10mm (0.5") side-by-side overlap using the print string as a guide. Keeping the same overlap parameters described in the first wrap, continue installing the Wrappingband strips until the entire ClickWeld fitting and cut-back area is covered with a ≥ 50 mm [2"] overlap onto the mainline/plant coating.



8. Installed STOPAQ® Wrappingband Inspection

Visual Inspection: The appearance of **STOPAQ® Wrappingband** must look smooth and tight and should be shaped around all details and into corners.

- *In full contact with the steel/coated substrate*
- *No cracks or holes in backing*
- *Proper overlap onto the mainline/factory coating. $\geq 50\text{mm}$ (2")*
- *No entrapped air*
- *No large wrinkles*
- *Proper wrap overlap during entire length of installation*

Holiday detection: Immediately after application of **STOPAQ® Wrappingband** holiday testing should be carried out with a voltage of 15 kV. A brush probe is recommended. No further testing is required.

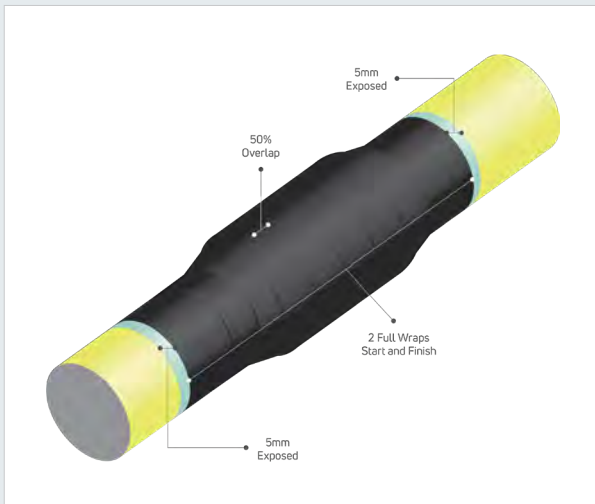

9. Outerwrap Application 1

ClickWeld fittings should be spirally wrapped from left-to-right or from right-to-left. In general, **STOPAQ® Outerwrap** should be applied with tension by gently pulling the roll of material. Start wrapping Outerwrap with two full circumferential wraps perpendicular to the pipe, leaving 3 mm of the previously applied **STOPAQ® Wrappingband** visible at the boundary.

After application of the circumferential wraps, consecutive spiral wraps should have an overlap of $\geq 50\%$. Avoid air inclusions. Avoid tenting and bridging.

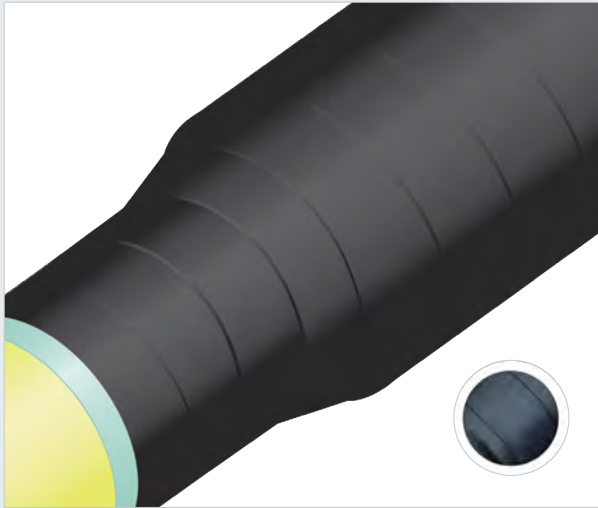

10. Outerwrap Application 2

Continue spiral wrapping until reaching the end of the Wrappingband, leaving 3 mm visible at the boundary. End wrapping with two full circumferential wraps perpendicular to the pipe. Final 75mm (3") should be applied without tension and the tape end should face downwards ending at 3 o'clock position. Cut off in a tie-form.

Installed Outerwrap Inspection

Visual inspection: The applied Outerwrap must look smooth and tight and should be shaped around all details and into corners.

- In full contact with the Wrappingband
- No cracks or holes in backing
- No large wrinkles
- Proper wrap overlap during entire length of installation



Stadskanaal, The Netherlands
Tel: +31 599 696 170 | info@sealforlife.com

Edmonton, Alberta Canada
Tel: 587 896 1312 | info@sealforlife.com

sealforlife.com

STOPAQ® DISCLAIMER: Seal For Life Industries warrants that the product conforms to its chemical and physical description and is appropriate for the use stated on the technical data sheet when used in compliance with Seal For Life Industries' written instructions. Because many installation factors are beyond the control of Seal For Life Industries, the user shall determine the suitability of the products for the intended uses and assume all risks and liabilities in connection herewith. Seal for Life's liability is stated in its General Terms and Conditions of Sale. Seal For Life Industries makes no other warranty either express or implied. All information contained in this technical data sheet is to be used as a guide and is subject to change without notice. This technical data sheet supersedes all previous data sheets on this product. Seal For Life Industries is a registered marks of the Berry Global Group, Inc. or its affiliates.

APPENDIX D
SCARGUARD APPLICATION GUIDE

Scar-Guard®

Composite Mechanical Protection for Directionally Drilled Pipelines for Field Joints

Product Description



Scar-Guard® (SCG) is supplied in a heat sealed foil pouch. Compression Film is supplied separately.

Equipment List



Appropriate tools for surface abrasion and preparation (wire brush/power wire brush or grit blaster, abrasive paper (60-80 grit), knife, lint free rags, approved solvent and high volume water sprayer, perforation tool, standard safety equipment: latex and leather gloves, safety glasses, hard hat, etc.

Preparation



Perform an SSPC SP1 solvent cleaning. Remove all visible signs of oil, grease, dust, dirt or other surface contaminants; clean the FJC and the adjacent pipe coating with a solvent cleanser. To determine the width of the area to be cleaned refer to step 5 or step 6.

For Epoxy Field Joint Coatings:

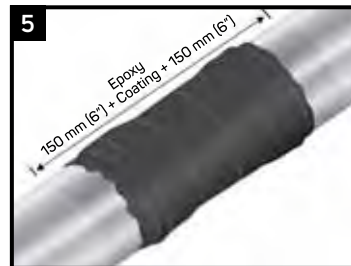

1. Sweep blast a minimum of 150mm (6") past the FJC edges on both sides. Sweep blasting should result in a 25 to 75 microns (1 to 3 mil) profile. Be careful not to cause a holiday when sweep blasting. With approval from the coating manufacturer, sweep blast the entire epoxy girth weld coating resulting in a 25 to 75 microns (1 to 3 mil) profile.
2. If sweep blasting isn't an option, thoroughly abrade the areas mentioned in step 1 above with 60 to 80 grade grit paper.
3. Blow down, wipe down or brush off the entire prepared area once prep is complete with noncontaminated equipment to remove dust.
4. Perform a Holiday Test to ensure that there are no holidays. If any are present, repair the girth weld coating in accordance with the manufacturer's recommendations and repeat steps 1-4.

For Heat Shrink Sleeves, Tapes, Etc:

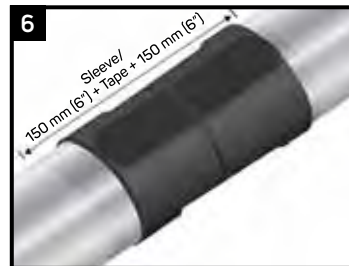

Do not sweep blast these types of field joint coatings.

1. If the mainline coating is an epoxy (FBE/ARO), sweep blast a minimum of 150mm (6") wide area past the FJC edges on both sides. Sweep blasting should result in a 25 to 75 micron (1 to 3 mil) profile. Be careful not to cause a holiday when sweep blasting. If sweep blasting isn't an option, thoroughly abrade the areas mentioned above with 60-80 grade grit paper.
2. If the mainline coating is a polyethylene or polypropylene do not sweep blast, thoroughly abrade the areas mentioned in step 1 above with 60-80 grade grit paper.
3. Blow down or wipe down or brush off the entire prepared area once prep is complete with noncontaminated equipment to remove the dust.
4. Perform a Holiday Test to ensure that there are no holidays. If any are present, repair the girth weld coating in accordance with the manufacturer's recommendations. and repeat steps 1-4.



The field joint coating (FJC) should be installed per the manufacturers recommended guidelines.

Outer Wrap Application Scar-Guard®



Water is needed to activate Scar-Guard®. Open the foil pouch, remove the roll. Once opened, the product cannot be repackaged. Scar-Guard® is activated using a high volume water sprayer to soak each layer as it is wrapped. Impermeable gloves (ie. Latex / rubber) are required during the Scar-Guard® installation.

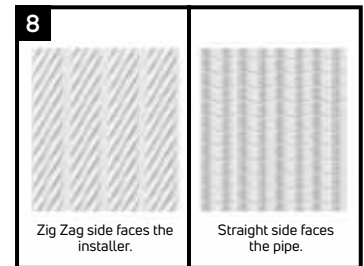

SCG must be wrapped onto the field joint in the correct orientation as shown above. The "Zig Zag" side of the SCG is the side that must face outward towards the installer. (Zig Zag Out). The straight side of the SCG is the side that must contact the pipe's surface.

2 Layer System

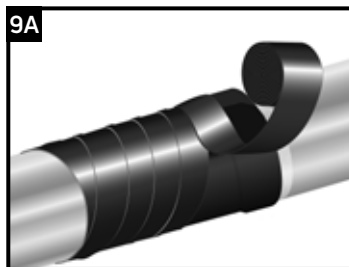

After preparation has been completed, soak the entire area to be wrapped with water. Open the foil pouch and remove the roll. Begin the application a minimum distance of 150 mm (6") past the corrosion coating edge. Installation can start on the leading or trailing edge. Apply the first wrap circumferentially around the pipe at a 90° angle, then begin spiral wrapping with a 50% overlap towards the other edge. Apply tension during application by pulling firmly on the roll as it is applied. Squeeze and mold firmly in the direction of the wrap until tight. THOROUGHLY SOAK each layer (both sides, top, and bottom) of the SCG as it is being applied, not just the outer layer. Continue with the 50% overlap until the SCG extends to the other edge of abraded area created in step 5. (a minimum distance of 150 mm (6") beyond the corrosion coating) SCG is applied in a minimum single pass with 50% overlap to achieve a 2-layer system. End with a minimum of one complete circumferential wrap at a 90° angle.

4 Layer System

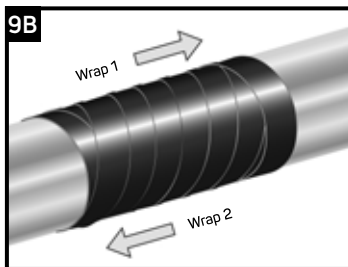

After preparation has been completed, soak the entire area to be wrapped with water. Open the foil pouch and remove the roll. Begin the application at a minimum distance of 150 mm (6") beyond the corrosion coating. Installation can start on the leading or trailing edge. Apply the first wrap circumferentially around the pipe at a 90° angle, then begin spiral wrapping with a 50% overlap towards the other edge. Apply tension during application by pulling firmly on the roll as it is applied. Squeeze and mold firmly in the direction of the wrap until tight. THOROUGHLY SOAK each layer (both sides, top, and bottom) of the SCG as it is being applied, not just the outer layer. Continue with the 50% overlap until the SCG extends a minimum distance of 150 mm (6") beyond the corrosion coating on the other edge. Switch directions and continue to spiral wrap with a 50% overlap towards the edge where the installation started.

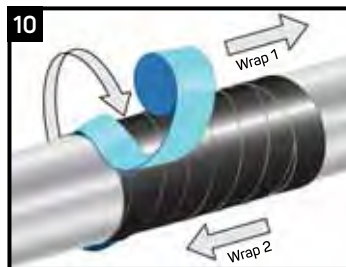

Apply the compression film **immediately** after the Scar-Guard has been installed. Apply the compression film in the same spiral direction as the SCG with a 50% overlap. Start min. 150 mm (6") beyond the outer edge of the SCG, pulling firmly during application to compress all SCG layers together, and end 150 mm (6") past the SCG on the opposite edge. The compression film must be installed with a minimum of 4 layers thick (2 passes at 50% overlap). Apply compression film with high tension.

NOTE: Compression film should be applied before excess foaming is observed and the resin has exceeded the gel time. The compression film must be applied and perforated immediately after the installation of the SCG.

Prior to Pulling

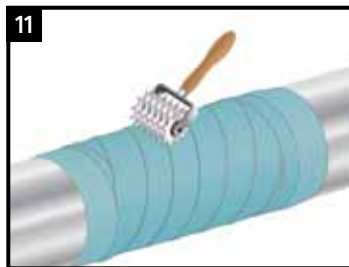

Perforate the compression film using the perforation tool immediately after installation of all the layers. Use enough downward force to perforate the compression film ONLY. Leather gloves can be worn during this step. Perforation allows the CO₂ gas generated by the curing process, and excess water, to escape. Compression film should remain in place as long as possible, and should only be removed prior to installation of pulling the pipe in. The film will help protect the SCG from UV degradation should the pullback be delayed. If a UV resistant SCG is required, please contact your local Canusa representative.

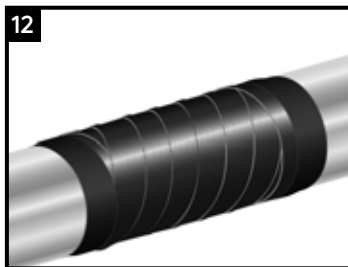

Allow SCG to reach a Shore D Hardness of 60 prior to pulling. SCG is fully cured at a Shore D Hardness of 80 at 23°C (72°F).

Shore D readings should only be taken over resin only in a flat area. Shore D readings taken over grooves, resin poor fibers or foamed resin areas may result in lower values.

Hot & Cold Weather Installations

Contact your Canusa-CPS representative for cold and hot weather application techniques.
[Cold ≤ 10°C (50°F), Hot ≥ 40°C (100°F)]

Storage & Handling

For ideal shelf life, store in a cool, shaded area at ambient temperature 23°C (72°F). Do not expose to temperatures above 44°C (110°F) or below 5°C (40°F). Do not open bag containing Scar-Guard (SGC) until you are ready to use it, as SGC cures when exposed to atmospheric moisture/humidity.

Do not stack more than 3 cartons high. Do not remove the Scar-Guard pouches from the boxes and store separately.

Care must be taken when handling the sealed bags to prevent puncturing or scuffing. If the protective foil pouch is punctured, the composite wrap will cure within the sealed foil pouch.

Expiration dates are found on each individual bag.

These installation instructions are intended as a guide for standard products. Consult your Canusa representative for specific projects or unique applications.

Canada

SFL Canusa Canada
333 Bay Street, Suite 2400
Toronto ON M5H 2T6, Canada

info@canusacps.com

USA

3813A Helios Way, Suite 900
Pflugerville, TX 78660

info@canusacps.com

Europe

Elskensakker 8
5571 SK Bergeijk
The Netherlands (NL)

Tel: +31 497 54 25 27

Middle East

Plot # 37-WR43, Sector no.: ICAD III
Musaffah South, PO Box 2621
Abu Dhabi, United Arab Emirates

Tel: +971 (2) 204 9800

Quality Management system registered to ISO 9001

Canusa warrants that the product conforms to its chemical and physical description and is appropriate for the use stated on the installation guide when used in compliance with Canusa's written instructions. Since many installation factors are beyond our control, the user shall determine the suitability of the products for the intended use and assume all risks and liabilities in connection therewith. Canusa's liability is stated in the standard terms and conditions of sale. Canusa makes no other warranty either expressed or implied. All information contained in this installation guide is to be used as a guide and is subject to change without notice. This installation guide supersedes all previous installation guides on this product. E8/OE

Part No. 99060-228

IG_Scar-Guard_rev014



CORE LINEPIPE

APPENDIX E: FLANGE BOLT UP SPECIFICATION

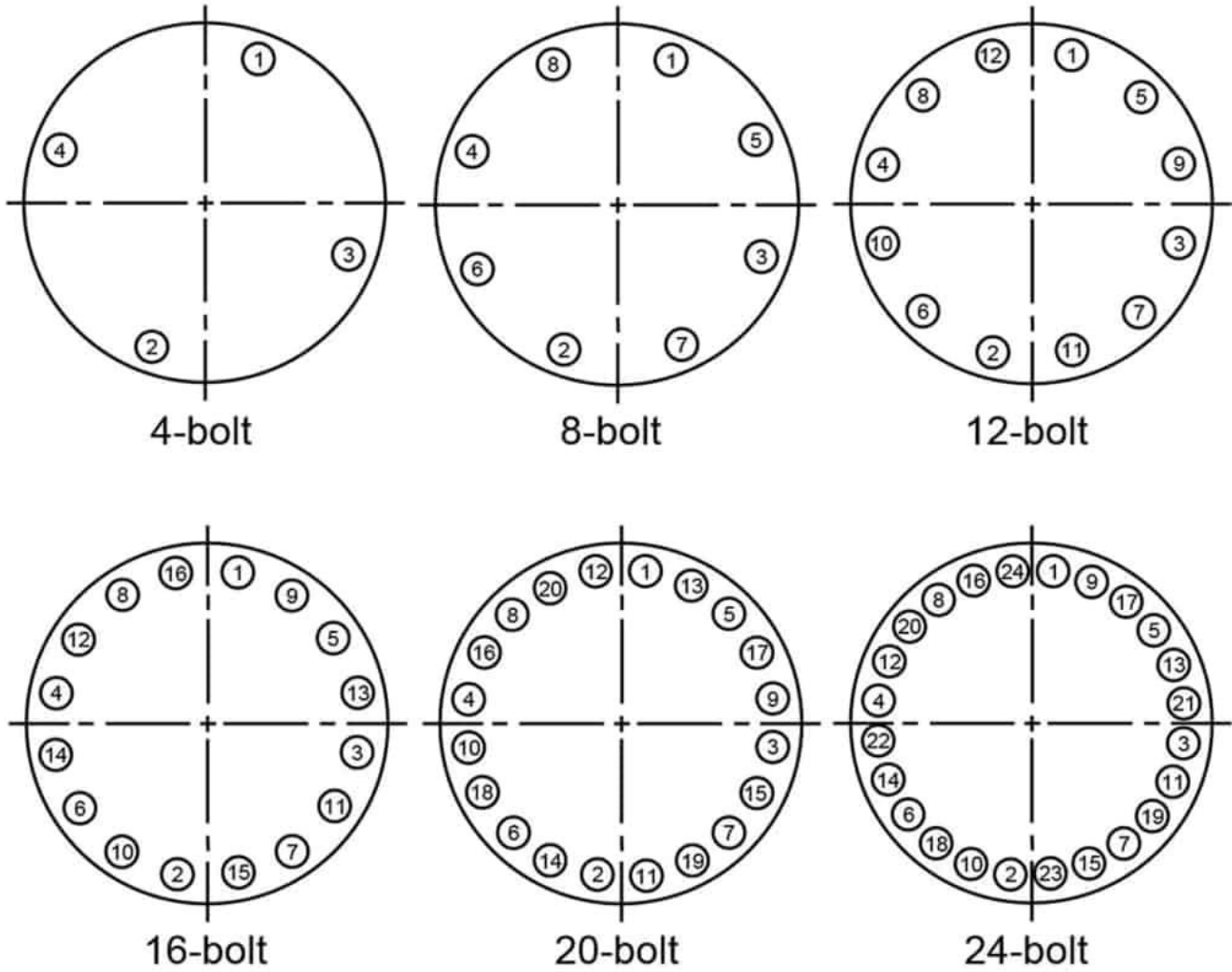

R01g

WWW.CORELINEPIPE.COM

The information contained in this document is confidential and is the property of CORE Linepipe. Any reproduction in part or as a whole without the written permission of CORE Linepipe is prohibited.

Flange Size	Type of Compression Ring***	Step 1 Repeat 2X	Step 2 Repeat 2X	Step 3 Repeat 2X	Step 4 Repeat 2X	Step 5	Step 6 Repeat as many times as necessary until all nuts are at final torque and compression ring is tight**
4" – 300 ANSI	Standard	80 ft-lbs	150 ft-lbs	300 ft-lbs	N/R	Wait at least 1 hour*	300 ft-lbs
4" – 300 ANSI	High Performance	80 ft-lbs	150 ft-lbs	300 ft-lbs	N/R		300 ft-lbs
4" – 600 ANSI	Standard	80 ft-lbs	150 ft-lbs	300 ft-lbs	400 ft-lbs		400 ft-lbs
4" – 900 ANSI	High Performance	80 ft-lbs	150 ft-lbs	300 ft-lbs	500 ft-lbs		500 ft-lbs
4" – 1500 ANSI	High Performance	80 ft-lbs	160 ft-lbs	390 ft-lbs	650 ft-lbs		650 ft-lbs
6" – 300 ANSI	Standard	80 ft-lbs	150 ft-lbs	300 ft-lbs	N/R		300 ft-lbs
6" – 300 ANSI	High Performance	80 ft-lbs	150 ft-lbs	300 ft-lbs	N/R		300 ft-lbs
6" – 600 ANSI	Standard	80 ft-lbs	150 ft-lbs	300 ft-lbs	500 ft-lbs		500 ft-lbs
6" – 900 ANSI	High Performance	80 ft-lbs	150 ft-lbs	360 ft-lbs	600 ft-lbs		600 ft-lbs
6" – 1500 ANSI	High Performance	80 ft-lbs	200 ft-lbs	500 ft-lbs	820 ft-lbs		820 ft-lbs
8" – 300 ANSI	Standard	80 ft-lbs	150 ft-lbs	300 ft-lbs	400 ft-lbs		400 ft-lbs
8" – 600 ANSI	Standard	80 ft-lbs	150 ft-lbs	360 ft-lbs	600 ft-lbs		600 ft-lbs
12" – 300 ANSI	Standard	80 ft-lbs	300 ft-lbs	500 ft-lbs	700 ft-lbs		700 ft-lbs
12" – 600 ANSI	Standard	80 ft-lbs	300 ft-lbs	500 ft-lbs	850 ft-lbs		850 ft-lbs
12" – 900 ANSI	High Performance	80 ft-lbs	400 ft-lbs	800 ft-lbs	1130 ft-lbs	1130 ft-lbs	

*The plastic flange will relax over time. The longer you wait, the less cycles in step 6 will be necessary to reach final torque.

**It is very important that the steel compression ring between the flanges is being compressed between the steel flanges.

Standard Compression Ring

High Performance Compression Ring

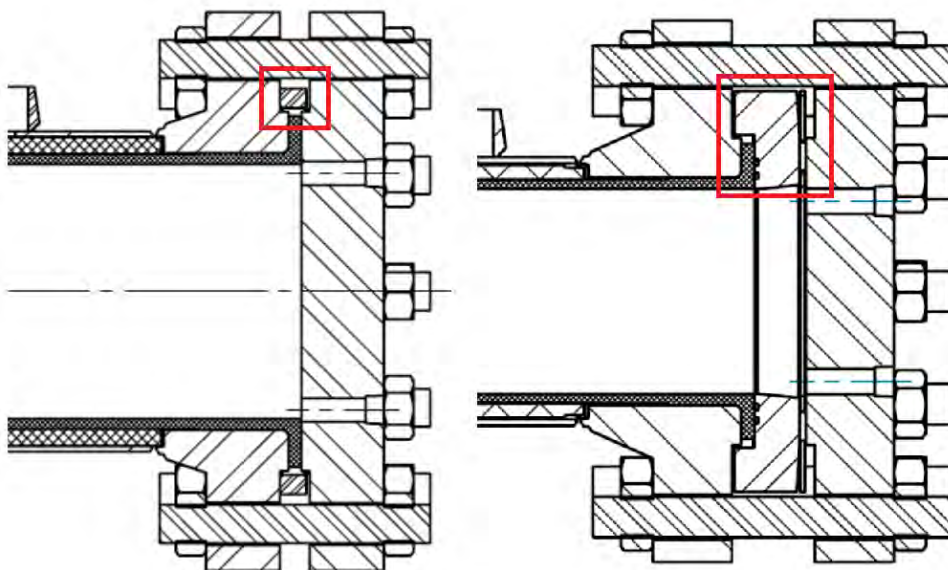

WWW.CORELINEPIPE.COM

The information contained in this document is confidential and is the property of CORE Linepipe. Any reproduction in part or as a whole without the written permission of CORE Linepipe is prohibited.

Flange Size	Stud Spec				Nut Spec	
	Size	Length Single*	Length Double*	Material	Size	Material
4" – 300 ANSI	0.75"-10 UNC	6"	6"	A193 B7M OR A320 L7M STUD	0.75"-10 UNC HEAVY HEX NUT	A194 2HM OR 7M
4" – 300 ANSI HP	0.75"-10 UNC	6"	6"		0.75"-10 UNC HEAVY HEX NUT	
4" – 600 ANSI	0.875"-9 UNC	7"	7"		0.875"-9 UNC HEAVY HEX NUT	
4" – 900 ANSI	1.125"-7 UNC	8"	8"		1.125"-7 UNC HEAVY HEX NUT	
4" – 1500 ANSI	1.25"-7 UNC	10"	10"		1.25"-7 UNC HEAVY HEX NUT	
6" - 300 ANSI	0.75"-10 UNC	6"	6"		0.75"-10 UNC HEAVY HEX NUT	
6" - 300 ANSI HP	0.75"-10 UNC	7"	7"		0.75"-10 UNC HEAVY HEX NUT	
6" - 600 ANSI	1"-8 UNC	8"	8"		1"-8 UNC HEAVY HEX NUT	
6" - 900 ANSI	1.125"-7 UNC	10"	10"		1.125"-7 UNC HEAVY HEX NUT	
6" - 1500 ANSI	1.375"-8 UNC	14"	14"		1.375"-8 UNC HEAVY HEX NUT	
8" - 300 ANSI	0.875"-9 UNC	6"	8"		0.875"-9 UNC HEAVY HEX NUT	
8" - 600 ANSI	1.125"-7 UNC	8"	8"		1.125"-7 UNC HEAVY HEX NUT	
12" – 300 ANSI	1.125"-7 UNC	8"	8"		1.125"-7 UNC HEAVY HEX NUT	
12" – 600 ANSI	1.25"-7 UNC	10"	10"		1.25"-7 UNC HEAVY HEX NUT	
12" – 900 ANSI	1.375"-8 UNC	12"	12"		1.375"-8 UNC HEAVY HEX NUT	

Note:

- * Single – CORE LINEPIPE flange to standard flange (either a customer flange, or blind flange)
- Double – CORE LINEPIPE flange to CORE LINEPIPE flange

Revision History

Date	By	Revision	Changes
2020-07-28	W. Chen	R01d	- Added compression ring type to table with illustration - Updated stud lengths
2022-03-08	W. Chen	R01e	- Added 12in products
2022-03-17	J. Saroop	R01f	- Added 4"-300 ANSI HP and 6"-300 ANSI products
2022-10-27	W. Chen	R01g	- Updated bolt tightening sequence

WWW.CORELINEPIPE.COM

The information contained in this document is confidential and is the property of CORE Linepipe. Any reproduction in part or as a whole without the written permission of CORE Linepipe is prohibited.

APPENDIX F: EXOTHERMIC WELDING BULLETIN

CORE Liner® Exothermic Welding

I. Background

CORE Liner® is a pipe-in-pipe system that utilizes an outer steel pipe for structural strength and an inner polymer liner pipe for corrosion resistance. The outer steel pipe is joined using the proprietary Clickweld® mechanical interference fit joining system, eliminating the need for steel welding in the field. The inner polymer liner is joined using electrofusion fittings. CORE Liner® combines the strength of carbon steel and the corrosion resistance of polymers.

II. Exothermic Welding

Exothermic welding can be used to weld electrical conductors to the CORE Liner® system. In order to avoid the risk of having the exothermic weld potentially damage the HDPE lining of the CORE Liner® pipe, CORE Linepipe requires having the exothermic weld be performed either on the Clickweld® ring or on the flange ring. The exothermic weld must not be performed on the CORE Liner® pipe, on the expanded surface of the Clickweld® bell, or on the bell transition area. The below sketches reflect the acceptable locations for the exothermic weld:

A. Clickweld® Area

CORE Liner® – Acceptable Locations for Exothermic Weld

Clickweld® Area

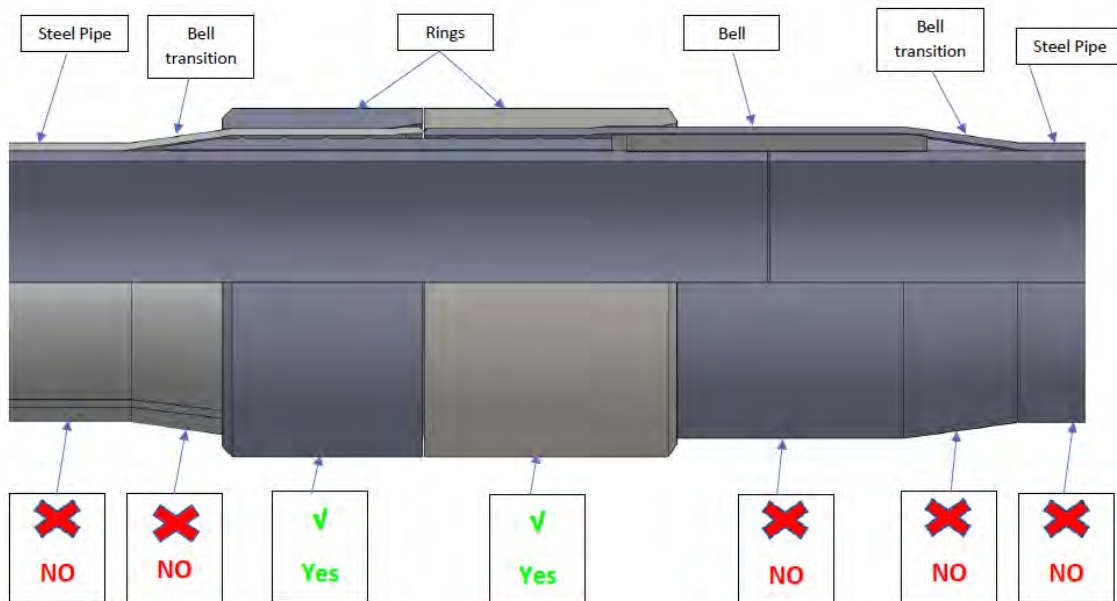

B. Flange Area

CORE Liner® – Acceptable Locations for Exothermic Weld

Flange Area

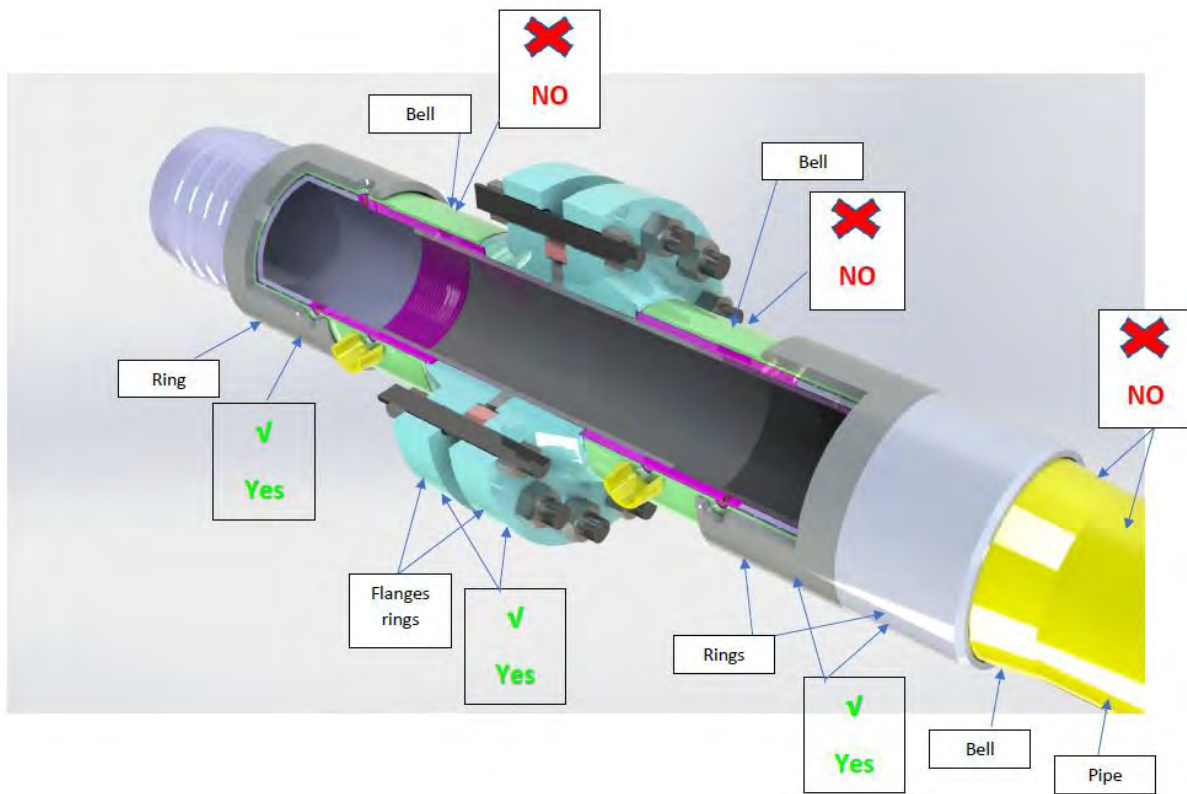

APPENDIX G: HYDROTEST PROCEDURE

CORE Liner® Hydrotest Procedure

1. One hydrotest, not two.

As CORE Liner® is a factory-built pipe in pipe system, both the carbon steel pipeline, as well as the internal lining system are simultaneously joined in the field. Accordingly, both the carbon steel pipeline and the internal lining of the CORE Liner® pipeline system are field hydrotested jointly rather than independently. In line with the CSA Z662 requirements for lined pipeline systems, a CORE Liner® pipeline would undergo the strength test aimed at confirming the structural integrity of the carbon steel pipeline, and is immediately followed by the leak test aimed at confirming the leak tightness of the internal lining.

2. Required Water Volume

The amount of water required to fill and pressurize the CORE Liner® pipeline can be estimated as follows:

Product	CL440	CL640	CL648	CL671
Volume of water	425 ft ³ /mile (7.5 m ³ /km)	1,000 ft ³ /mile (18 m ³ /km)	975 ft ³ /mile (17.5 m ³ /km)	925 ft ³ /mile (16.5 m ³ /km)

Product	CL856	CL1071	CL1279
Volume of water	1,675 ft ³ /mile (30 m ³ /km)	2,600 ft ³ /mile (46 m ³ /km)	3,675 ft ³ /mile (65 m ³ /km)

3. Recommended Test Procedure for a Completed Pipeline

CORE Linepipe® recommends the following hydrotest procedure in accordance with the relevant sections of CSA Z662 (Section 4, 8, 13). As per CSA Z662 clause 8.7.1.1, piping intended for operation at pressures greater than 700 kPa shall successfully undergo a strength test followed by a leak test. Vent lines are to remain open for all tests. Fill the pipeline with water by using water under pressure to push a medium density foam pig along the pipeline length, thus filling the pipeline with water while minimizing the potential for having air pockets. It is important to record the hydrotest information while the test is being performed. This will help in troubleshooting should the hydrotest become problematic. Please record the hydrotest details using the CORE Linepipe Hydrotest Report form.

3.1 Strength test:

As per CSA Z662 Table 8.1, it is required to perform the strength test at a minimum pressure of 1.25 x MAOP for water, oil and oil emulsion lines (sweet or sour LVP service fluids). The hydrotest shall be performed such that the hydrotest pressure of 1.25 x MAOP is applied at the pipeline section located at the lowest elevation. The actual test pressures at pipeline sections located at higher elevations will be dictated by the elevation profile of the pipeline.

N.B. The test pressure of 1.4 x MAOP required by the Alberta Pipeline Rules only applies to sour gas pipelines and is generally not applicable to CORE Liner® pipelines.

Rating	300 ANSI (PN 50)		600 ANSI (PN 100)		900 ANSI (PN 150)	
Product	All		All		CL640	
Maximum Allowable Operating Pressure	MAOP 720 psi (4.96 MPa)		MAOP 1440 psi (9.93 MPa)		MAOP 1780 psi (12.29 MPa)	
a. Fill line, removing all trapped air.						
b. Bump to pressure and hold for 60 minutes per 1000m of the longest distance between vents on the pipeline. For example, if the longest distance between vents on the line is 1500m, time should be 90 minutes.	50 psi 0.3 MPa		50 psi 0.3 MPa		50 psi 0.3 MPa	
c. Bump to pressure and hold for 15 minutes or until stable or rising pressure is achieved.	300 psi 2.1 MPa		500 psi 3.4 MPa		500 psi 3.4 MPa	
d. Bump to pressure and hold for 15 minutes or until stable or rising pressure is achieved.	500 psi 3.4 MPa		1000 psi 6.9 MPa		1200 psi 8.3 MPa	
e. Bump to pressure and hold for 15 minutes or until stable or rising pressure is achieved.	700 psi 4.8 MPa		1500 psi 10.3 MPa		1800 psi 12.4 MPa	
f. Bump to pressure and hold until stable or rising pressure is achieved. It is not uncommon to see small amounts of fluid from the vent ports during this portion of the test.	Min	Max ^{1,3}	Min	Max ^{1,3}	Min	Max ^{2,3}
	900 psi 6.2 MPa	1125 psi 7.8 MPa	1800 psi 12.4 MPa	2225 psi 15.3 MPa	2225 psi 15.3 MPa	2475 psi 17.1 MPa
g. Adjust the pressure to the appropriate test pressure, and hold for at least 4 hours. Ambient temperature fluctuations will affect the recorded pressure. A flat or slightly increasing pressure is desired over the 4-hour hold period. A slight pressure drop over the hold period combined with a quick reduction in the rate of the pressure drop typically indicates the pressure is stabilizing rather than the presence of a leak.						

Rating	900 ANSI (PN 150)		900 ANSI (PN 150)		900 ANSI (PN 150)	
Product	CL648		CL1071		CL1279	
Maximum Allowable Operating Pressure	MAOP 2140 psi (14.74 MPa)		MAOP 1950 psi (13.44 MPa)		MAOP 1830 psi (12.61 MPa)	
a. Fill line, removing all trapped air.						
b. Bump to pressure and hold for 60 minutes per 1000m of the longest distance between vents on the pipeline. For example, if the longest distance between vents on the line is 1500m, time should be 90 minutes.	50 psi 0.3 MPa		50 psi 0.3 MPa		50 psi 0.3 MPa	
c. Bump to pressure and hold for 15 minutes or until stable or rising pressure is achieved.	500 psi 3.4 MPa		500 psi 3.4 MPa		500 psi 3.4 MPa	
d. Bump to pressure and hold for 15 minutes or until stable or rising pressure is achieved.	1200 psi 8.3 MPa		1200 psi 8.3 MPa		1200 psi 8.3 MPa	
e. Bump to pressure and hold for 15 minutes or until stable or rising pressure is achieved.	2200 psi 15.2 MPa		2000 psi 13.8 MPa		1800 psi 12.4 MPa	
f. Bump to pressure and hold until stable or rising pressure is achieved. It is not uncommon to see small amounts of fluid from the vent ports during this portion of the test.	Min	Max ^{2,3}	Min	Max ^{2,3}	Min	Max ^{2,3}
	2675 psi 18.4 MPa	2970 psi 20.5 MPa	2440 psi 16.8 MPa	2710 psi 18.7 MPa	2290 psi 15.8 MPa	2540 psi 17.5 MPa
g. Adjust the pressure to the appropriate test pressure, and hold for at least 4 hours. Ambient temperature fluctuations will affect the recorded pressure. A flat or slightly increasing pressure is desired over the 4-hour hold period. A slight pressure drop over the hold period combined with a quick reduction in the rate of the pressure drop typically indicates the pressure is stabilizing rather than the presence of a leak.						

Rating	900 ANSI (PN 150)	1500 ANSI (PN 250)	1500 ANSI (PN 250)			
Product	CL440 & CL671	CL440	CL671			
Maximum Allowable Operating Pressure	MAOP 2160 psi (14.89 MPa)	MAOP 2620 psi (18.09 MPa)	MAOP 3160 psi (21.81 MPa)			
a. Fill line, removing all trapped air.						
b. Bump to pressure and hold for 60 minutes per 1000m of the longest distance between vents on the pipeline. For example, if the longest distance between vents on the line is 1500m, time should be 90 minutes.	50 psi 0.3 MPa	50 psi 0.3 MPa	50 psi 0.3 MPa			
c. Bump to pressure and hold for 15 minutes or until stable or rising pressure is achieved.	500 psi 3.4 MPa	800 psi 5.5 MPa	1000 psi 6.9 MPa			
d. Bump to pressure and hold for 15 minutes or until stable or rising pressure is achieved.	1200 psi 8.3 MPa	1800 psi 12.4 MPa	2200 psi 15.2 MPa			
e. Bump to pressure and hold for 15 minutes or until stable or rising pressure is achieved.	2200 psi 15.2 MPa	2800 psi 19.3 MPa	3400 psi 23.4 MPa			
f. Bump to pressure and hold until stable or rising pressure is achieved. It is not uncommon to see small amounts of fluid from the vent ports during this portion of the test.	Min	Max^{1,3}	Min	Max^{2,3}	Min	Max^{2,3}
	2700 psi 18.6 MPa	3350 psi 23.1 MPa	3275 psi 22.6 MPa	3640 psi 25.1 MPa	3950 psi 27.2 MPa	4390 psi 30.3 MPa
g. Adjust the pressure to the appropriate test pressure, and hold for at least 4 hours. Ambient temperature fluctuations will affect the recorded pressure. A flat or slightly increasing pressure is desired over the 4-hour hold period. A slight pressure drop over the hold period combined with a quick reduction in the rate of the pressure drop typically indicates the pressure is stabilizing rather than the presence of a leak.						

¹ Based on ASME B16.5 Group 1.1 materials (e.g. ASTM A 350 LF2 class 1 or CSA Z 245.12 GR 359)

² Equivalent to 100% of pipe SMYS

³ It is permitted to exceed the maximum pressure by up to 0.3 MPa (50 psi) during pressure stabilization.

3.2 Liner leak test:

- Following the successful completion of the strength test, de-pressurize the line to between 0.03 and 0.1 MPa (5 and 15 psig) at the high end of the pipeline and hold for a duration of 1 hour. This is to allow the liner to relax, thus facilitating the detection of test liquids in the unlikely event of a liner breach.
- Increase the pressure to between 2 and 2.2 MPa (290 to 320 psi) at the highest section of the pipeline and stabilize the pressure at a minimum of 2 MPa (290 psi) until a flat or slightly increasing pressure is achieved.
- Hold the pressure for 4 hours. Ambient temperature fluctuations will affect the recorded pressure. A flat or slightly increasing pressure is desired over the hold period. A slight pressure drop over the hold period combined with a quick reduction in the rate of the pressure drop typically indicates the pressure is stabilizing rather than the presence of a leak.
- During the liner leak test, the vents on the annular space shall be periodically monitored for flow of liquids.

3.3 De-pressure/De-water the line.

4. Recommended Test Procedure for a Bore Section:

As an additional safeguard, CORE Linepipe® recommends conducting a pre-test on pipeline sections intended to be pulled in a pipeline bore. The pre-test would be conducted while the assembled section is above ground, and as follows:

- Vent lines are to remain open for the strength test and the leak test.
- Plugs, seals, and caps are to be properly installed.
- No external coating is to be installed prior to the hydrotest.
- Use only medium density foam pigs.
- Install a digital pressure gauge to monitor bore pressure.
- Record the test details on the CORE Linepipe Hydrotest Report form.
- Conduct the strength test as per section 3.1, except that:
 - Step b.: Bump to pressure and hold for at least 15 minutes and until there is no air flow at the vents.
 - Step g.: Adjust the pressure to the appropriate test pressure, and hold for at least 30 minutes.
- Conduct the leak test as per section 3.2, except that:
 - Step c.: Hold the pressure for 30 minutes.
- De-water/de-pressure line.

CORE Linepipe Hydrotest Report

Test Date	
Customer	
Job Number	
Pipeline Dia	
Test Section Length	
High Point Elevation	
Low Point Elevation	

Test Section Start LSD	
Test Section End LSD	
High Point Riser LSD	
High Point Riser Elevation	
Low Point Riser LSD	
Low Point Riser Elevation	
Pressure Sensor Location	

Test Pressure	
Test Medium	
Water Source	
Antifreeze Type and %	
Mixture Temperature	

Gauge Number	
Dead Weight Number	
Chart Recorder Number	

QC Inspector	
Signature	
Date	

Owner's Inspector	
Signature	
Date	

APPENDIX H: RETURNING MATERIAL



RETURN MATERIAL AUTHORIZATION

Document #: QF-0840-21

Revision: 5

RMA #:		Date:	
Customer:		Estimated Return Date:	
Sales Order #:		Items sold by CORE? (Y/N)	
Release #:		Items sold by Distributor? (Y/N)	
		Distributor Name:	

Return Product Information

Indicate what type of items are being returned (Yes/No):

Pipe		(Ancillary items are flanges, shrink sleeves, etc.)
Risers/Bends		
Ancillary		

	Quantity (pcs)	Quantity (meters for pipe)
Product or Item:		
Product or Item:		
Product or Item:		

*If more than 3 items, please use the Notes section below.

Reason for Return

Authorization/Approval to invoice charges for:

(Please put Yes or No in the boxes below)

Handling	
Inspection	
Repair labour/ materials	
Restocking fee	
Storage	

Core to Invoice charges to:

(Please put Yes or No in the boxes below)

Distributor	
Customer	

Do you authorize CORE Linepipe to accept this return?

--	--	--

Name & Company Signature Date

Notes or special instructions:

APPENDIX I: START UP, OPERATION & SHUT DOWN BULLETIN

CORE Liner® Startup, Operation and Shutdown

I. Background

CORE Liner® is a pipe-in-pipe system that utilizes an outer steel pipe for structural strength and an inner polymer liner pipe for corrosion resistance. The outer steel pipe is joined using the proprietary ClickWeld® joining system, eliminating steel welding in the field. The inner polymer liner is joined using electrofusion fittings. CORE Liner® combines the strength of carbon steel and the corrosion resistance of polymers. Similar to other piping systems, CORE Liner® should be operated in accordance with the requirements of CSA Z662 and the applicable regulations.

II. Startup

After the pipeline has been hydrotested and commissioned, the routine startup procedure of a CORE Liner® system should include a controlled and gradual flow increase to allow the pipeline to gradually adjust to the temperature and pressure of the operating fluid. It is recommended to have the pipeline vents open during the pipeline pressurization. The aim is to allow the gas that is present in the annular space to vent out, and to check that the liner is leak tight, i.e. no bore liquids are able to reach the annular space.

III. Venting

Gas molecules have a natural ability to very slowly move through piping materials. This is called gas permeation. Gas permeation occurs through polymer materials at a higher rate than through metallic materials. In the case of lined steel products, the permeated gas can gather in the annular space of the pipeline and increase the pressure of the annular space. As described in CSA Z662 clause 13.2.8.1, and similar to other lined pipelines, it is important to regularly vent the annular space of the CORE Liner® pipeline. This is achieved by routinely opening the vent ports provided at the CORE Liner® flanged connections. The vents should be kept open until the venting almost stops. For pipelines in multiphase or gas service, and depending on the pipeline operating parameters and distance between vents, adequately venting the annular space may take up to few hours. Consult CORE Linepipe for project specific guidance.

The venting frequency should be determined by the operating company based on the specific operating parameters of each pipeline. CORE Linepipe recommends venting the pipeline system at least once every month. If the venting duration turns out to be excessive, the venting interval can be reduced to achieve a reasonable venting duration. It is required to vent pipelines containing a gas phase in the bore and subject to operating pressure fluctuations as frequently as practical to keep the annular pressure as low as possible.

IV. Depressurization

The annular space of CORE Liner® should be vented prior to depressurizing the pipeline bore. It is required to depressurize the bore slowly to allow the gas that permeated the liner to fully vent out of the annular space. It is also recommended to continuously control the bore depressurization rate by monitoring the pressure in the pipe bore and the annular space to ensure the liner is never subjected to a buckling pressure. This is particularly important for pipelines containing a gas phase. Depressurizing the bore while the annular space is still under pressure may result in liner buckling and possibly collapse.

V. Vacuum

CORE Liner® is generally able to resist full vacuum. Nevertheless, to prevent liner collapse, the pipeline vents should not be opened while the liner is under vacuum conditions. In addition, in services where vacuum is expected to last for more than one hour per occurrence, countermeasures such as vacuum breakers are recommended as an additional level of protection.

VI. Pigging

CORE Liner® may be pigged using medium-density foam pigs or custom made polyurethane disk pigs. Typically, medium-density foam pigs are used for dewatering, while polyurethane disk pigs are used for removing wax buildup. Steel wire brush pigs should not be used with CORE Liner® as they may scrape and damage the polymer liner. The pipeline should be pigged frequent enough to prevent any substantial buildup from occurring. Pigging a pipeline containing a substantial buildup or blockage may result in pipeline damage or in the pig getting stuck. It is recommended to vent the system immediately before and after the pigging to confirm that the liner is leak tight, i.e. no bore fluids are coming out of vents.

VII. Hot Oiling

Where hot oiling a CORE Liner® is needed, the pressure and temperature during the hot oiling should not exceed the following values:

	ANSI 300	ANSI 600	ANSI 900	ANSI 1500
Maximum Allowable Pressure	4,960 kPa (720 psig)	9,930 kPa (1440 psig)	14,740 kPa (2140 psig)	CL440: 18,070 kpa (2620 psig) CL671: 21,810 kPa (3160 psig)
Maximum Allowable Temperature	60 °C (140 °F)			

It is recommended to vent the pipeline immediately before the hot oiling to avoid the potential of buckling the liner as a result of the liner softening during the hot oiling. It is also recommended to vent the pipeline after the hot oiling to confirm that the liner is leak tight, i.e. no bore fluids are coming out of vents.

VIII. Alcohol Injection

The internal HDPE layer of CORE Liner® is resistant to alcohols. Methanol and ethanol can be used with CORE Liner® both in continuous dosing or as batch treatment. If continuous alcohol dosing is used, adequate countermeasures should be in place to mitigate the effects of the potential presence of oxygen in the alcohol being injected.

IX. Cathodic Protection

The carbon steel pipes, flanges and ClickWeld® components of the CORE Liner® system are interconnected over the length of the pipeline without interruption, which provides a continuous electrical path on the CORE Liner® pipeline from flanged end to flanged end. Standard cathodic protection typically used on coated carbon steel pipelines may be used on CORE Liner® pipelines.

®/™ Trademark(s) of CORE Linepipe. CORE Linepipe, ClickWeld, CORE Liner, CORE Service and CORE Coat are registered trademarks of CORE Linepipe.



CORE LINEPIPE

UNITED STATES

200, 2002 Timberloch Place
The Woodlands, Texas 77380
Toll Free: 1.855.445.8889

CANADA

910, 736 – 8th Avenue S.W.
Calgary, Alberta T2P 1H4
Phone: 587.333.6685

info@corelinepipe.com
www.corelinepipe.com